



48' Diameter Unstiffened Bin

**40-Series Bin - 4.00" Corrugation
6000 lbs. Peak Load Roof for IDC**

Construction Manual

PNEG-2048

Version: 2.1

Date: **10-08-20**



PNEG-2048

All information, illustrations, photos and specifications in this manual are based on the latest information available at the time of publication. The right is reserved to make changes at any time without notice.

Contents

Chapter 1 Safety	5
Safety Guidelines	5
Cautionary Symbols Definitions	6
Safety Cautions	7
Safety Sign-Off Sheet	11
Chapter 2 Decals	12
Chapter 3 General Overview	14
General Information	14
Tools Required for Construction	14
Guidelines for Proper Storage of Grain Bin Materials Prior to Construction	15
Overview for a Typical Bin Installation	15
Guidelines for Construction Procedures and Lifting Jack Usage	16
Instructions for Stirring Devices	17
Guidelines for Placement of the Decal Sidewall Sheet	18
Chapter 4 Foundations	19
Foundation Recommendations	19
Selecting the Proper Site Location	19
Scribe the Diameter	19
Foundation Forms	20
Preparing the Foundation Forms	20
Placing the Reinforcement	21
Anchor Bolt Detail	21
Anchor Bolt Charts	22
Placement of the Vane Axial Fan Foundation	23
Placement of the Centrifugal Fan Foundation	24
Frost Free Foundation Recommendations	25
Inverted "T" Foundation (3000 PSF Soil Bearing Capacity)	27
Base Angle Installation	28
Chapter 5 Hardware Requirements	29
Bolt and Nut Pairings	29
Hardware for Sidewall Sheets on 4" Corrugation Bins 12' to 48' Diameter	29
Bolt Torque Specifications	30
Identifying Bolt Grades	30
Bolt Identification	31
Color Chart for Bin Hardware Bucket Lids	33
Chapter 6 Assembling Sidewall Sheets	34
Guidelines for Constructing Sidewall Sheets	34
Color Codes for Sidewall Gauge Identification	34
Orientation Detail for Top Sidewall Sheets	35
Caulking and Bolting Detail for Standard Sidewall Sheets	36
Chapter 7 Door Assembly	38
Door Placement	38
2 Ring Door Installation	39
Two-Ring Door Latch Assembly	45
Options for 2 Ring Door - Bin Step	46

Table of Contents

Chapter 8 Roof Assembly	47
Installing the Roof Rafter Bracket to the Sidewall	47
Installing the Eave Clip and Intermediate Eave Angle to the Sidewall Sheet	48
Attaching the Roof Stiffener Clips to the Rafter	49
Center Collar Placement	50
Assembling the Center Collar	50
Assembling the Roof Flashing Angle	51
Assembling the Rafters	52
Attaching the Rafter Assembly to Roof Rafter Bracket	53
Attaching the Rafter Assembly to Center Collar	54
Assembling the Purlin	55
Installing the Tension Rods	56
Installing the Temperature Cable Support Brackets (Optional)	57
Installing the Roof Panels	59
Installing the Roof Flashing	62
Roof Ring Placement (Optional)	64
Installing a Roof Ring	65
Chapter 9 Accessories	67
Assembling the Ladder Section	67
Installing the Platform Support	68
Installing the Eave Adjustable Braces to Extension Rails and Roof	69
Assembling the Platform and Handrail	71
Assembling the Eave Safety Cage Hoop	72
Safety Cage Hoop Adjuster Plate Connection Details	73
Installing the Vertical Supports	73
Assembling the Safety Cage	74
Assembling the 24" Safety Cage Bell Section	75
Chapter 10 Warranty	77

Safety Guidelines

Safety guidelines are general-to-specific safety rules that must be followed at all times. This manual is written to help you understand safe operating procedures and problems that can be encountered by the operator and other personnel when using this equipment. Read and save these instructions.

As owner or operator, you are responsible for understanding the requirements, hazards, and precautions that exist and to inform others as required. Unqualified persons must stay out of the work area at all times.

Alterations must not be made to the equipment. Alterations can produce dangerous situations resulting in **SERIOUS INJURY** or **DEATH**.

This equipment must be installed in accordance with the current installation codes and applicable regulations, which must be carefully followed in all cases. Authorities having jurisdiction must be consulted before installations are made.

When necessary, you must consider the installation location relative to electrical, fuel and water utilities.

Personnel operating or working around equipment must read this manual. This manual must be delivered with equipment to its owner. Failure to read this manual and its safety instructions is a misuse of the equipment.

ST-0001-4

Cautionary Symbols Definitions

Cautionary symbols appear in this manual and on product decals. The symbols alert the user of potential safety hazards, prohibited activities and mandatory actions. To help you recognize this information, we use the symbols that are defined below.



This symbol indicates an imminently hazardous situation which, if not avoided, **will result in serious injury or death.**



This symbol indicates a potentially hazardous situation which, if not avoided, **can result in serious injury or death.**



This symbol indicates a potentially hazardous situation which, if not avoided, **can result in minor or moderate injury.**



This symbol is used to address practices not related to personal injury.



This symbol indicates a general hazard.



This symbol indicates a prohibited activity.



This symbol indicates a mandatory action.

ST-0005-2

Safety Cautions

Use Personal Protective Equipment

- Use appropriate personal protective equipment:

Eye Protection



Respiratory Protection



Foot Protection



Hearing Protection



Head Protection



Fall Protection



Hand Protection



- Wear clothing appropriate to the job.
- Remove all jewelry.
- Tie long hair up and back.

ST-0004-1

Follow Safety Instructions

- Carefully read all safety messages in this manual and safety signs on your machine. Keep signs in good condition. Replace missing or damaged safety signs. Be sure new equipment components and repair parts include the current safety signs. Replacement safety signs are available from the manufacturer.
- Learn how to operate the machine and how to use controls properly. Do not let anyone operate without instruction.
- If you do not understand any part of this manual or need assistance, contact your dealer.



ST-0002-1

Maintain Equipment and Work Area

- Understand service procedures before doing work. Keep area clean and dry.
- Never service equipment while it is operating. Keep hands, feet, and clothing away from moving parts.
- Keep your equipment in proper working condition. Replace worn or broken parts immediately.



ST-0003-1

1. Safety

Prevent Roof Damage Due to Vacuum Pressure

- Roof damage can result from excessive vacuum or internal pressure from fans or other air moving systems. The manufacturer does not warrant this type of roof damage.
- Adequate ventilation or “makeup air” devices must be provided for all powered air handling systems.
- The manufacturer does not recommend the use of downward flow systems (suction).
- Severe roof damage can result from any blockage of air passages.
- Running fans during high humidity or cold weather conditions can cause air exhaust or intake ports to freeze.

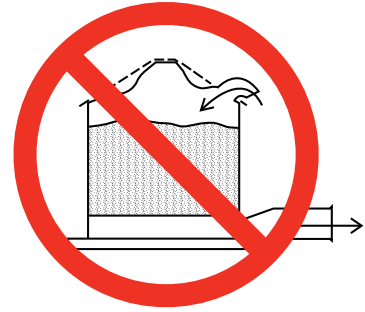

ST-0028-2

Unload the Bin Correctly

- Use CENTER FLOOR OUTLET ONLY until NO grain remains above this outlet.
- Side floor outlets to be used ONLY when above condition is satisfied.
- Lock all side floor outlets to avoid accidental premature use.
- See manufacturers instructions for proper use of factory supplied sidedraw (wall) discharge systems.

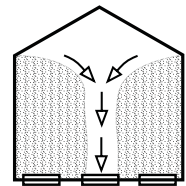
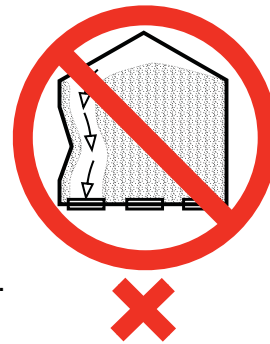

ST-0060-1

Sharp Edge Hazard

- This product has sharp edges, which can cause serious injury.
- To avoid injury, handle sharp edges with caution and always use proper protective clothing and equipment.



ST-0036-2

Rotating Auger Hazard

- Keep clear of rotating augers and moving parts.
- Do not remove or modify guards or covers.
- Lock-out power source before making adjustments, cleaning, or maintaining equipment.
- Failure to follow these precautions will result in serious injury or death.



ST-0037-1

Do Not Enter Bin

- Rotating flighting will kill or dismember.
- Flowing material will trap and suffocate.
- Crusted material will collapse and suffocate.
 - If you must enter the bin:
 1. Shut off and lock out all power sources.
 2. Use a safety harness and safety line.
 3. Station another person outside the bin.
 4. Avoid the center of the bin.
 5. Wear proper breathing equipment or respirator.



ST-0061-1

1. Safety

Stay Clear of Hoisted Equipment

- Always use proper lifting or hoisting equipment when assembling or disassembling equipment.
- Do not walk or stand under hoisted equipment.
- Always use sturdy and stable supports when needed for installation. Not following these safety precautions creates the risk of falling equipment, which can crush personnel and cause serious injury or death.



ST-0047-1

Do Not Overfill the Bin

- Do not overfill bin. Stored grain must be no higher than the roof eaves at the outer edge.
- Filling the bin above this point creates excessive internal pressure and can cause swelling and eventual roof failure. The over filling of a bin can also cause the blockage of roof vents and eaves, which will lead to a build-up of air pressure causing roof damage.

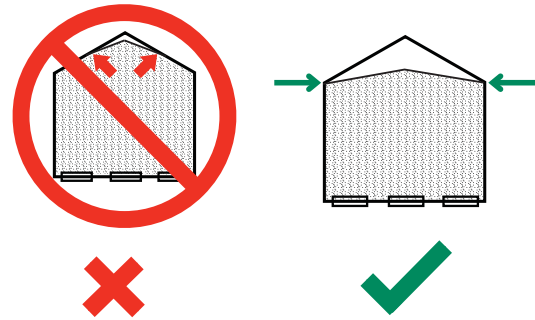

ST-0050-1

Install and Operate Equipment Properly

- This product is intended for the use of grain storage only. Any other use is a misuse of the product.



ST-0057-1

Store Bin Sheets Properly

- Sidewall bundles or sheets must be stored in a safe manner. The safest method of storing sidewall bundles is by laying them horizontally with the arch of the sheet upward, like a dome.
- Sidewall sheets stored on edge must be secured so that they cannot fall over and cause injury.
- Use care when handling and moving sidewall bundles.



ST-0058-2

2. Decals



The safety decals on your equipment are safety indicators which must be carefully read and understood by all personnel involved in the installation, operation, service and maintenance of the equipment.

To replace a damaged or missing decal, contact us to receive a free replacement.

GSI Decals

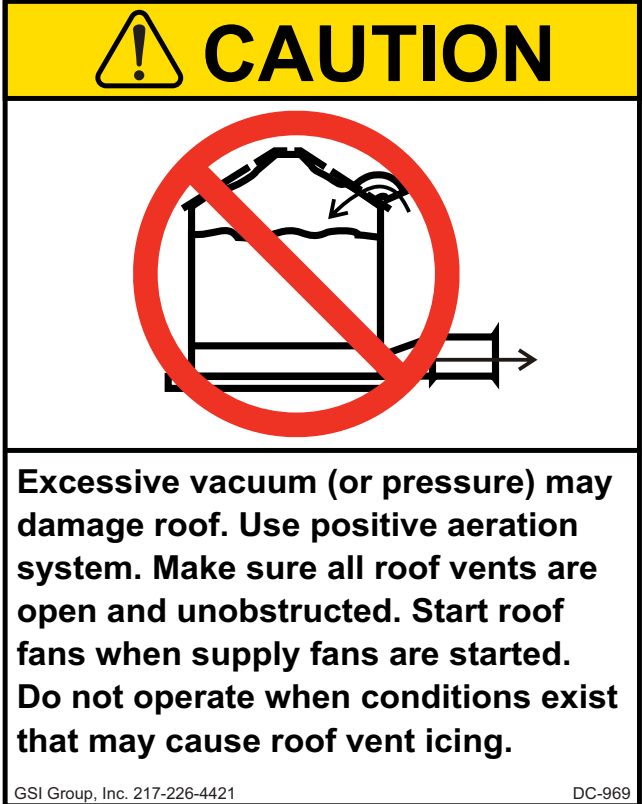
1004 E. Illinois St.
Assumption, IL. 62510
Phone: 1-217-226-4421

Location	Decal #	Decals	Description
Located next to aeration system.	DC-969		Caution Vacuum Pressure

Location	Decal #	Decals	Description
On bin door covers	DC-GBC-1A		Warning Keep Clear of Augers
On bin door covers	DC-GBC-2A		Warning Unload Instructions

3. General Overview

General Information

General information, overview and instructions needed before performing work.

Read this manual carefully. This manual will provide instructions on building the sidewall. You will also need to consult other instructions in building the bin.

These include, but may not be limited to:

1. A sidewall gauge layout chart. If such a chart is not included with this manual, contact GSI.
2. Roof instructions must be followed. Roof instructions are included in this manual.
3. Ladders, roof stairs, roof handrails and other products are covered by separate instruction manuals. Consult the appropriate accessory manual. Inside ladder instructions are included in this manual.
4. Aeration systems and transitions are to be installed according to the instructions provided with the system or transition.
5. It is critical that the anchor bolts are installed and spaced correctly.

Tools Required for Construction

General tools needed to perform this construction:

1. Combination wrench set 7/16" to 1".
2. Alignment punches 12" long.
3. 1/2" Drive socket set and ratchet.
4. Nail aprons or tool pouches to hold supplies.
5. Gloves for hand protection.
6. Tape measure.
7. 1/2" Drive electric or pneumatic torque gun with variable impact capabilities.
8. 1/2" Drive impact socket set.
9. Lifting jacks.
10. Center pole roof support.
11. Step ladders.
12. Large C-clamp or welding V-grip for clamping.

NOTE: *Quantities required will depend on the number of workers and size of the bin.*

Guidelines for Proper Storage of Grain Bin Materials Prior to Construction

Storage of the build materials prior to construction is important. Do not to allow moisture to remain between sheets or panels.

Wet storage stain (rust) will develop when closely packed bundles of galvanized material, such as sidewall and roof sheets, have moisture present. Inspect roof and sidewall bundles on arrival for any moisture. If moisture is present, it must not be allowed to remain between the sheets. Separate the sheets or panels immediately and wipe them down. Spray with a light oil or diesel fuel.

If possible, sidewall bundles, roof sheets and other closely packed galvanized materials should be stored in a dry, climate controlled building. If outdoor storage is unavoidable, the materials should be stored so that they are raised above the ground and vegetation. Any stacking and spacing materials should not be corrosive or wet. Be sure to protect materials from the weather, but permit air movement around the bundles if possible.

Storing roof bundles and sidewall sheets at a slight incline can also help minimize the presence of moisture. Storing the bundles with the center of the dome up (like an arch) is one option for minimizing moisture during storage. Sidewall bundles can also be stored on edge but must be secured so that they do not fall over and cause injury.

If “white rust” or “wet storage stain” occurs, contact the manufacturer immediately about ways to minimize the adverse effect upon the galvanized coating.

Overview for a Typical Bin Installation

These are the typical steps one would perform when constructing a grain bin. Procedures may vary depending on site requirements.

Pre-Assembly Activities

1. Sorting and grouping parts.

Assembly

1. Build one ring of sidewall sheets, making sure to caulk all seams.
2. Install the center collar tower support in the center of the bin.
3. Install eave clips and intermediate eave angles to the sidewall sheets. (Note how these are aligned.)
4. Install roof panels.
5. Install roof flashing.
6. Install peak cap.

3. General Overview

Guidelines for Construction Procedures and Lifting Jack Usage

1. Before constructing the bin, consider the location of the door and other accessories. Proper placement of lifting jacks in relationship to anchor bolts could make a difference on odd or even ring bins. Walk-through door is centered between two (2) stiffener anchor bolts. The sidewall sheets are also staggered 1/3 from end to end.
2. Anchor all jacks securely with metal stakes and cable.
3. Raise the bin just high enough to assemble the next ring. When lifting the bin, **crank all jacks equally**. This will prevent bowing the previously assembled rings and make for easier hole alignment. (See Figure 3A.)

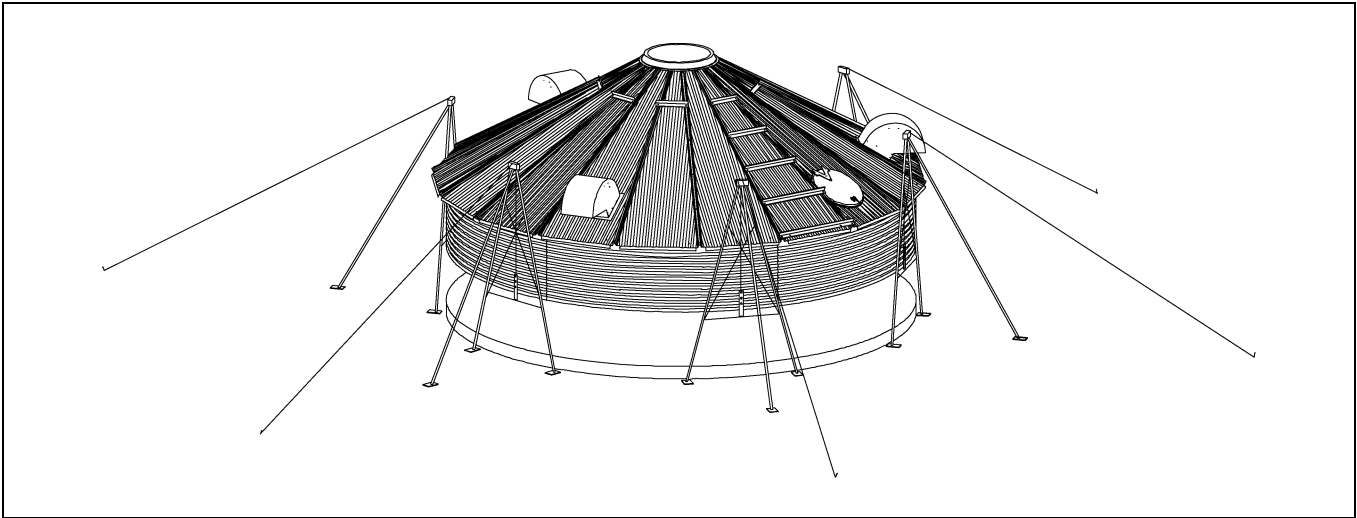

Figure 3A Lifting Jack

4. Bolt the next ring to the **inside** of the first ring. Be sure to **stagger** the sheets and select the proper gauge material.
5. Lower the bin onto the foundation after assembling and tightening bolts on the new ring or rings.
6. Re-bolt the lifting straps to the lowest ring in place thus far. Continue ring additions until ready for the door installation.

NOTE: The number of lifting jacks required is best determined by personal experience. Factors such as bin size, soil compaction, wind velocity, jack design, etc., are all to be considered when deciding how many to use. If in doubt, use one jack on every vertical seam. Be sure to use heavy duty jacks for commercial installation.

NOTE: Add inside and outside ladders to bin walls as you continue to raise the bin. (Refer to the manual supplied with the ladder.)

Instructions for Stirring Devices

Bins are offered in more than one structural series for specific uses. To maintain the warranty, the appropriate “series” grain bin must be used. Consult the sales catalog or contact the Engineering Department for current recommendations. Note that the use of any stirring device with three (3) or more vertical screws may require a heavier than “standard” series bin. Any re-circulating device or system should be used in the “re-circulating” series bins. **NOTE: For GSI bins larger than 48' diameter an alternate method of mounting is to attach suspension chain to intermediate center collar.**



Stirring devices may create additional loads on grain bin sidewalls, roofs and floors. If high-moisture grain is loaded too deep and too fast, unstiffened bin walls can become overloaded. Observe the following installation and operation procedures if the bin is to be equipped with the stirring device.

1. Read owner's manual for the stirring device and follow all instructions set forth by the manufacturer.

IMPORTANT: *Install the switch for the stirring device near the roof manway opening so that the unit can be observed while stirring.*

2. Make sure there are no obstructions, such as protruding ladders.
3. After loading approximately 3' of grain, run the unit one complete revolution to determine if it is working properly.
4. If the unit is functioning properly, operate the stirring device continuously while filling and drying to avoid compacted grain around the vertical screws.
5. If it becomes necessary to stop a stirring device using laterally moving screws, try to stop it with the vertical screws nearest to the center of the bin, away from the sidewall. Should a device stop or stall for any reason and remain inoperable for any length of time, the auger carriage should be supported to the grain surface before restarting. The vertical auger should be turned by hand, with a pipe wrench, before power is applied.
6. For best results, fill the bin to one-half of the final intended depth. Dry grain to 16% and continue filling. Use filling rates specified by stirring device manufacturer. If necessary to fill to the top without stopping, reduce the filling rate and drying air temperature so that the stirring rate can keep up with the drying rate.
7. Do not overfill bin. Filling should be stopped at bottom of top ring or 30" below the track.

NOTE: *The above steps are only general instructions which apply to the majority of stirring devices. Since there are different manufacturers of these devices, it is important to read the operator's manual thoroughly for specific instructions applicable to the machine.*

3. General Overview

Guidelines for Placement of the Decal Sidewall Sheet

Use the following as a general guideline the proper decal sheet placement.

NOTE: Refer to sidewall attachment detail and specific gauge sheet for the bin. The decal sheets are located in the top ring. They are to be spaced evenly around the diameter of the bin.

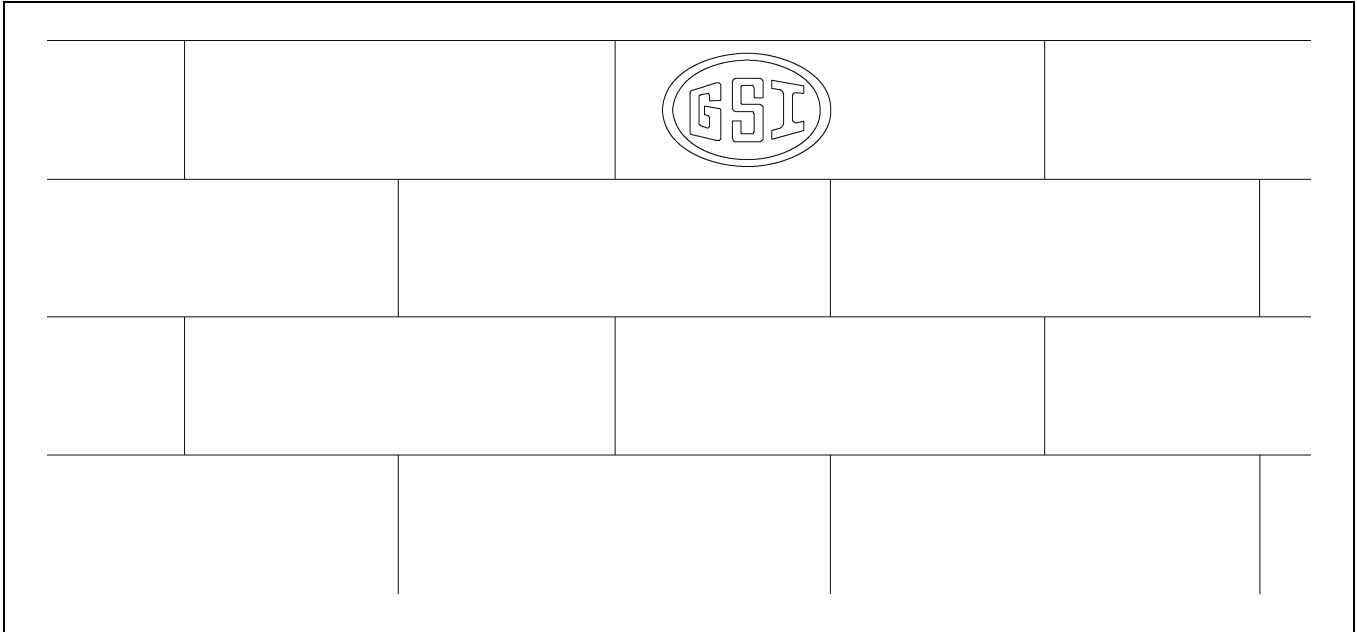

Figure 3B Decal Sidewall Sheet

Foundation Recommendations

These are general foundation recommendations. Site conditions, system requirements and other factors may create foundation construction requirements not covered by this manual.

Selecting the Proper Site Location

1. The selected site should be level, firm and free from underlying debris. The soil bearing capacity should be equal to or greater than required by the footing specifications.
2. The concrete foundation surface must be level. If fill is required, it should be watered and tamped thoroughly to prevent uneven settling from the weight of the bin.
3. The site should allow easy access for easy loading and unloading, as well as provide additional space for future units.
4. When selecting a bin site, also consider the positioning of handling equipment, fans, heaters, fuel lines and the availability of electricity.

Scribe the Diameter

1. Determine the center of the foundation site and drive a small 2 x 4 into the ground to mark it. Drive the stake into the ground so that it is the same height as the finished foundation will be.
2. Using one large spike, nail a straight 2 x 4 to the top of the center spike. This 2 x 4 should be approximately two feet (2') longer than the radius of the bin. The swiveling 2 x 4 will act as a compass, enabling you to scribe the correct diameter of the foundation and later locate the anchor and stiffener bolt locations. (See Figure 4A.)

NOTE: Making the 2 x 4 two feet (2') longer than the radius will allow the 2 x 4 to also be used as a leveling device and for pulling concrete.

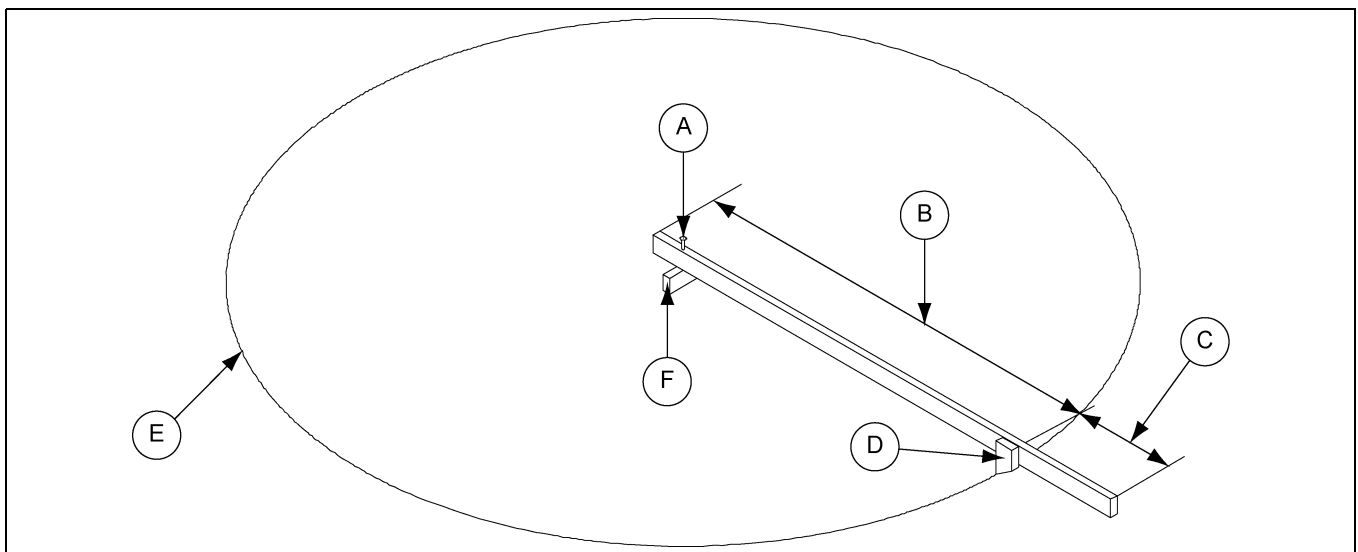

Figure 4A Scribe the Diameter

Ref #	Description
A	Spike
B	Foundation Radius
C	2'

Ref #	Description
D	Pointed Stake
E	Foundation Line
F	2 x 4 Center Stake

4. Foundations

Foundation Forms

Circular foundation forms are commonly used for stiffened farm bins.

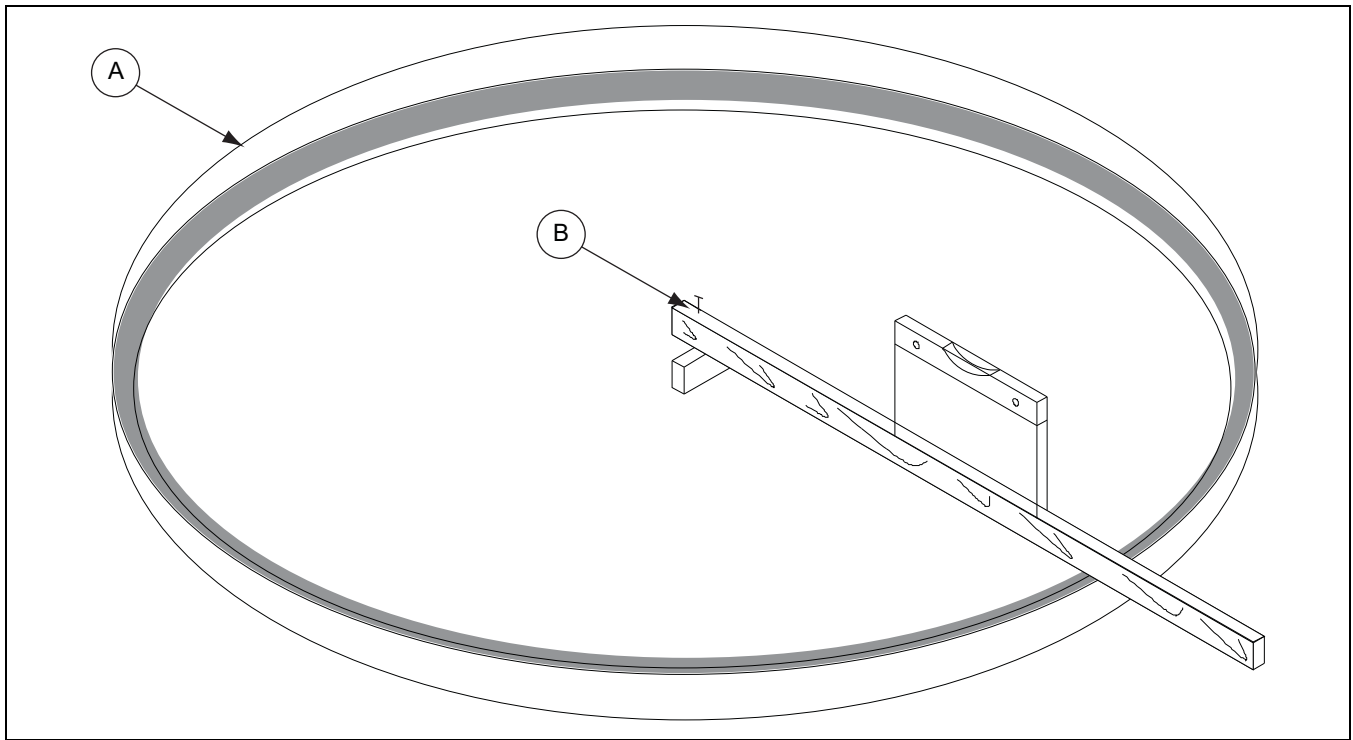

Figure 4B Circular Form

Ref #	Description
A	Footing Trench
B	Carpenter's Level

Preparing the Foundation Forms

1. Having scribed the diameter of the foundation, proceed by digging the foundation's footing, which consists of a large circular trench inside the foundation line.
2. Once the footing has been dug, you are ready to build the forms. The forms must be rigid enough to hold their shape against the poured concrete.
3. The foundation must be flat. Sloped floors cannot be used in drying bins. A carpenter's level placed on top of the compass 2 x 4 constructed earlier will enable you to set the top of the forms to match the top of the center stake.
4. Check the form work with a transit to ensure a uniform elevation for the entire foundation. The foundation should be level within 1/8" on non-stiffened tanks and within 1/4" on stiffened tanks at bin wall perimeter. Stiffened tanks must be shimmed level. Provisions for unloading system trenches, air ducts, etc., should be made as required by the particular material handling system used.

NOTE: All foundation specifications shall be construed as recommendations only. Because of the many variable conditions in an actual installation, manufacturer assumes no liability for results arising from the use of such recommendations.

Placing the Reinforcement

1. Once the forms and trench have been prepared, begin placing the reinforcement rods and mesh in the foundation's footing. Make sure the reinforcement rods are properly lapped by wiring.
2. Place at least 2" of compacted sand on the inside section of the foundation to provide a good base for the concrete and to protect against rodents.
3. Cover the sand with 4 ml. polyethylene plastic, which will act as a moisture barrier.
4. Add two (2) layers of 6" x 6" wire mesh to the entire area of the foundation slab or the entire foundation for monolithic systems to complete the preparation of the bin's foundation.

Anchor Bolt Detail

The following is the minimum requirement for anchoring of standard tanks.

1. 5/8" Diameter anchor bolt (A) is the minimum allowed, 3/4" diameter anchor bolt (A) is the minimum with sidedraw flume system.
2. Exposed anchor bolt thread height (B) for 5/8" and 3/4" diameter anchor bolts are 3" (7.6 cm) and 5" (12.7 cm) respectively.
3. Overall anchor bolt length (C) for 5/8" and 3/4" diameter anchor bolts are 12" (30.48 cm) and 18" (45.72 cm) respectively. *(See Figure 4C.)*

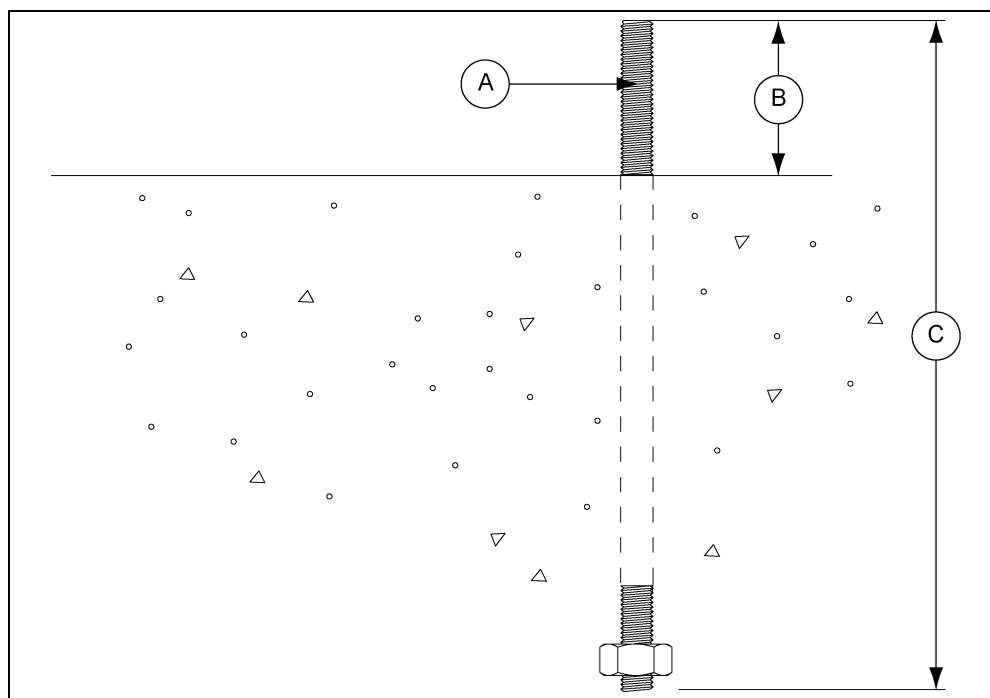

Figure 4C Anchor Bolt Example (3/4" Diameter Anchor Bolt Shown)

Ref #	Description
A	Anchor Bolt
B	Anchor Bolt Thread Height
C	Anchor Bolt Length

4. Foundations

Anchor Bolt Charts

Prior to setting any anchor bolts, you must be sure to have the correct anchor bolt placement.

NOTE: Refer to proper chart to find the anchor chord dimensions that correspond to the bin that is being built.

Scribe the radius location of the anchor bolts by using a center stake and a straight 2 x 4. Along the scribed radius, start with one anchor bolt and work counterclockwise to locate one quarter of the anchor bolts then clockwise to locate another quarter of the anchor bolts. Working off of the last anchor bolts in each quarter, locate the remaining anchor bolts in the last two (2) quarters.

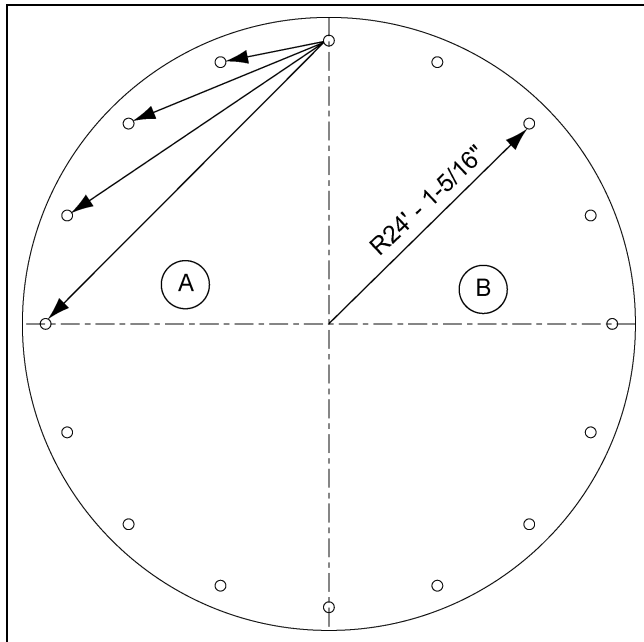

Figure 4D Anchor Bolt Chords for 48' Diameter Unstiffened Bin (4" Corrugation) 3-9 Rings

Ref #	Description
A	Anchor Chord Dimensions
B	Bolt Radius

Diameter	48'	
# of Anchors	16	
Bolt Radius	24' - 1-5/16"	7.35 m
Chord 1	9' - 4-7/8"	2.88 m
Chord 2	18' - 5-7/16"	5.63 m
Chord 3	26' - 9-7/16"	8.17 m
Chord 4	34' - 1-1/8"	10.39 m

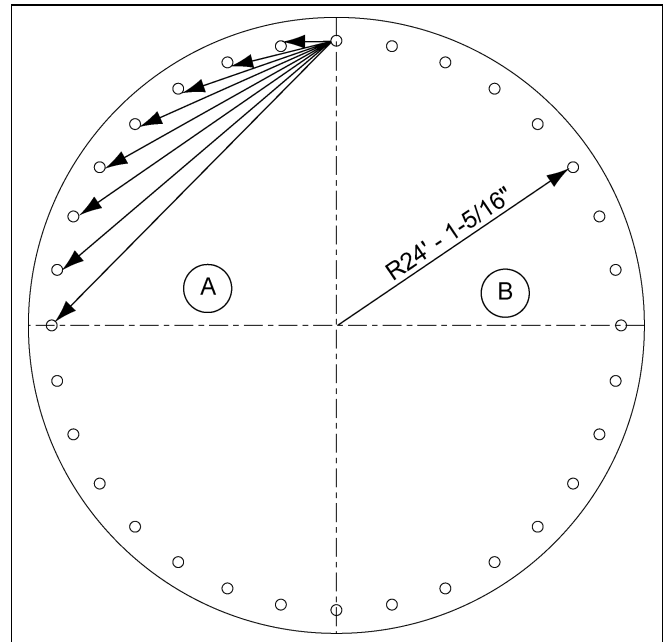

Figure 4E Anchor Bolt Chords for 48' Diameter Unstiffened Bin (4" Corrugation) 10 Rings

Ref #	Description
A	Anchor Chord Dimensions
B	Bolt Radius

Diameter	48'	
# of Anchors	32	
Bolt Radius	24' - 1-5/16"	7.35 m
Chord 1	4' - 8-11/16"	1.44 m
Chord 2	9' - 4-7/8"	2.88 m
Chord 3	13' - 11-15/16"	4.27 m
Chord 4	18' - 5-7/16"	5.63 m
Chord 5	22' - 8-3/4"	6.93 m
Chord 6	26' - 9-7/16"	8.17 m
Chord 7	30' - 7-1/16"	9.32 m
Chord 8	34' - 1-1/8"	10.39 m

Placement of the Vane Axial Fan Foundation

If a fan or fan and heater combination is to be installed, determine the concrete foundation size.

1. The top of the fan foundation should be level with the top of the bin's foundation.
2. Recommended foundation thickness is 4" minimum.
3. The front of the foundation should be perpendicular to the bin wall.
4. Concrete foundation for the heater is not required. If it is to be added, pour the concrete to cover the locations of both the heater and the fan. (See Figure 4F.)



The foundation and fan must be level and smooth for proper operation. Improper leveling can cause vibration problems.

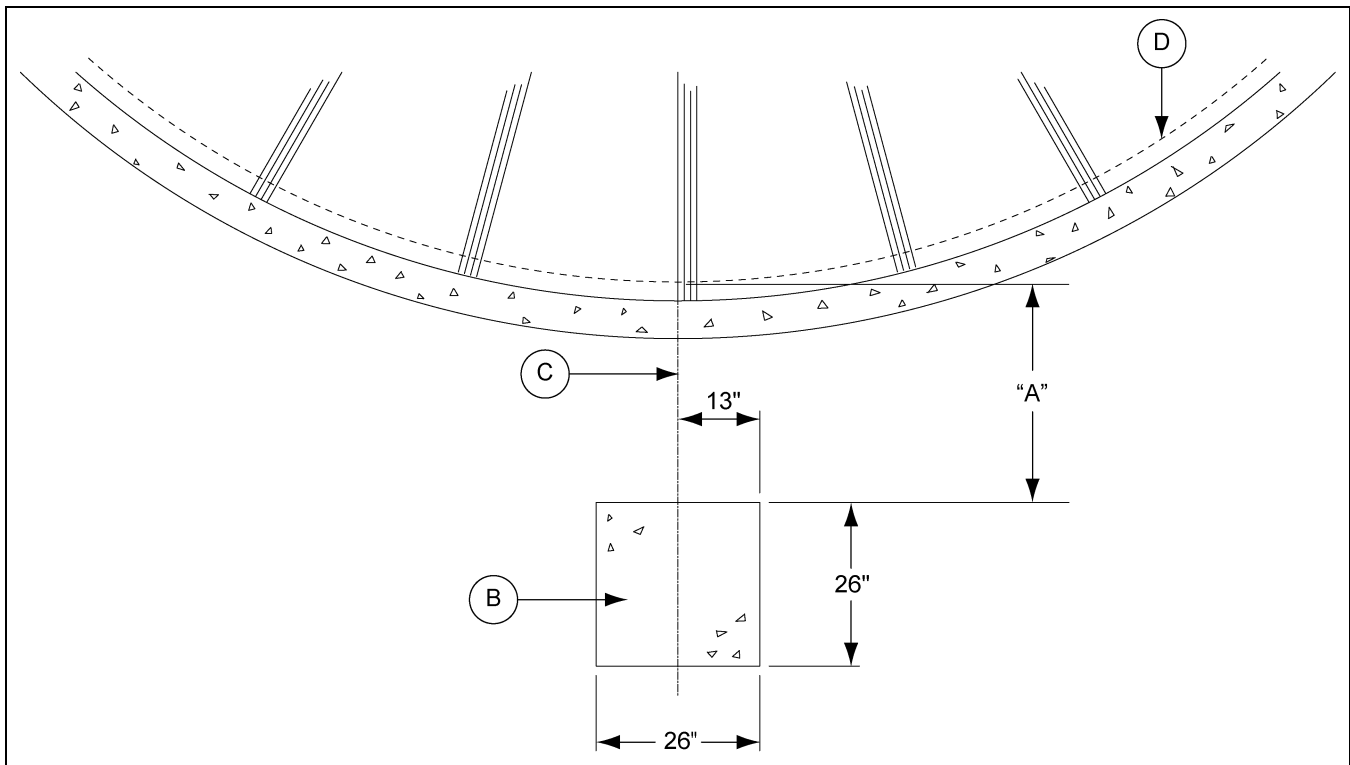

Figure 4F Vane Axial Fan Foundation

Ref #	Description
B	Fan Foundation
C	Bin Center
D	Bin Wall

Transition	Distance between Fan Foundation and Bin Wall (A) for Fans without Heaters (in.)	Distance between Fan Foundation and Bin Wall (A) for Fans with Heaters (in.)
TR-4734	20	44
TR-6918 and TR-6919	32	55
TR-7048	45	69
TR-8006	46	70

4. Foundations

Placement of the Centrifugal Fan Foundation

1. A correct fan foundation should be poured 2" below the top of bin foundation for all centrifugal fans.
2. A foundation for heaters is not required, but is recommended.
3. Recommended foundation thickness is 4".
4. If a downwind heater foundation is to be installed, the foundation width (F) should be 48" and extended towards the bin by 33".
5. The fan discharge should be centered on the centerline of the bin.
6. The fan foundation should be perpendicular to the bin wall. (See Figure 4G.)



The fan foundation and fan must be level and smooth for proper operation. Improper leveling can cause vibration problems.

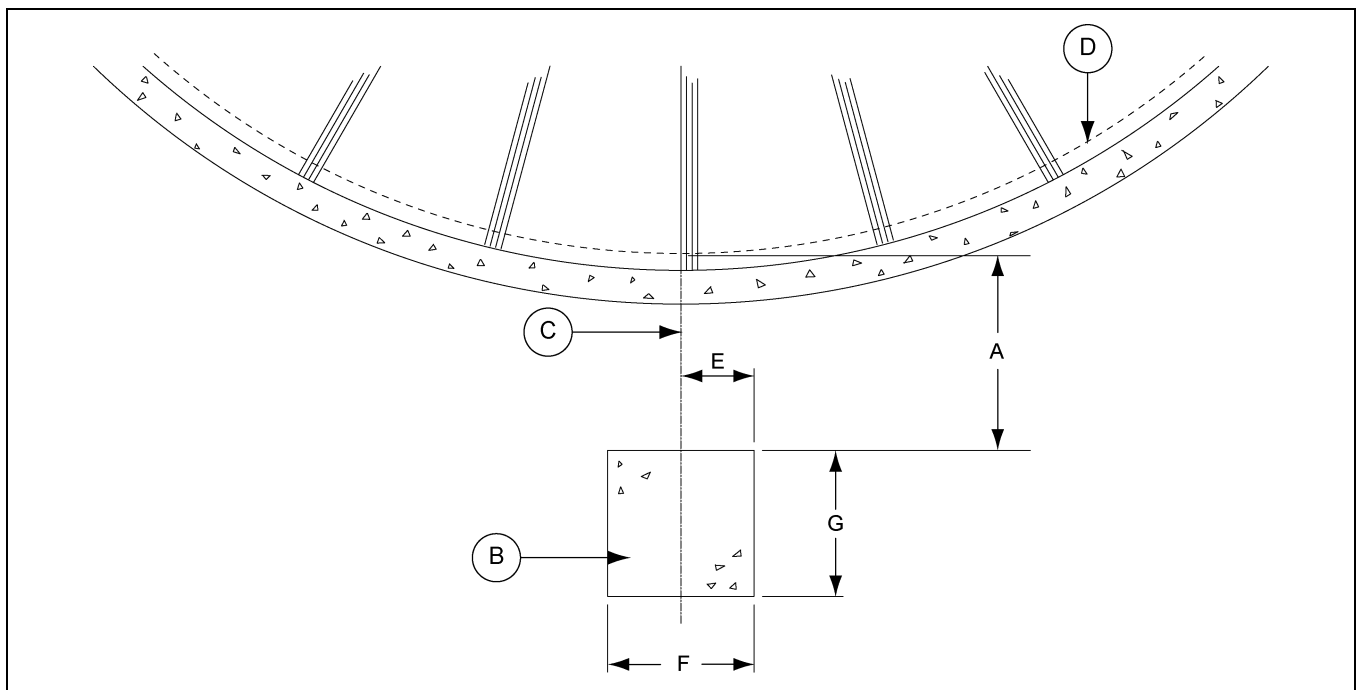

Figure 4G Centrifugal Fan Foundation

Ref #	Description
B	Fan Foundation
C	Bin Center
D	Bin Wall

Transition	Distance between Fan Foundation and Bin Wall (A) for Fans without Heaters (in.)	Distance between Fan Foundation and Bin Wall (A) for Fans with Heaters (in.)	E (in.)	F (in.)	G (in.)
TR-4734	20	44	10	40	40
TR-7048	45	-	10	40	48
TR-6918 and TR-6919	32	65	13	48	52
TR-7049	45	78	13	48	52
TR-6207	42	75	13	48	60
TR-6958 (Double Inlet)	55	85	13	48	60
TR-6853 (Double Inlet)	54	88	28	100	60

Frost Free Foundation Recommendations

The foundation design is based on a minimum allowable soil bearing capacity 3000 PSF. Bearing capacity of the soil should be determined by geotechnical investigation and be of uniform bearing capacity.

1. All reinforcement must meet the requirements of ASTM A615 grade 60 deformed bars.
2. Concrete must have a minimum compressive strength of 4000 PSI at 28 days, 6% to 8% air entrainment and 4" slump.
3. The foundation site must be free of vegetation and debris and well drained.
4. The foundation must be founded below the frost line or placed on non expansive frost free fill.
5. Lap all circumferential bars 35 bar diameters and stagger all laps in plans 3'.

NOTE: Estimates do not include end laps.

6. All material used for backfill inside the ring wall should be clean, well graded, crushed rock or a sand and gravel mixture. Backfill should be placed in 6" lifts, 95% compaction. (See Figure 4H.)

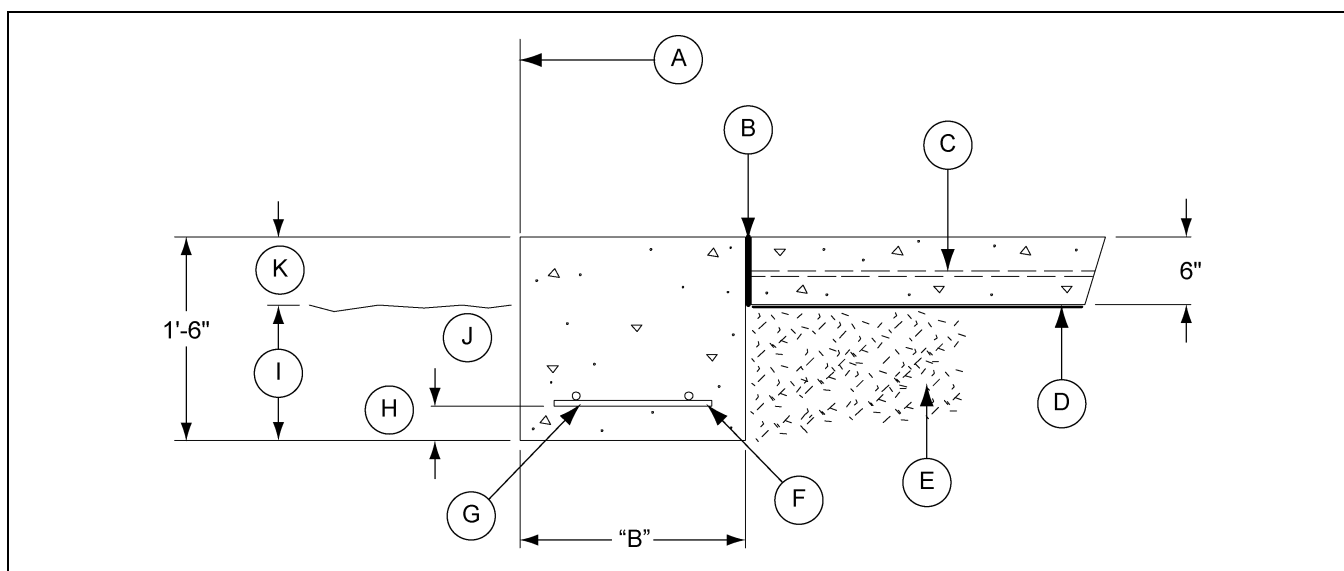

Figure 4H Frost Free Foundation

Ref #	Description
A	Outside Radius
B	1/2" Expansion Joint
C	Two (2) Layers 6 x 6 - 6/6 Wire Mesh
D	Vapor Barrier
E	Well Compacted Fill
F	"N" #6 Bars Evenly Spaced
G	#6 Bars at 12" c/c Required Only if "B" is Greater than 2'-0"
H	3" Cl.
I	1'-0" Minimum
J	Grade
K	6" Maximum

4. Foundations

NOTE: All foundation specifications are recommendations only. Due to many variable conditions in actual installation, the manufacturer assumes no liability for results arising from the use of such recommendations.

NOTE: Make sure to contact the manufacturer's engineering department for additional information for heights more than 6".

NOTE: The optional #4 rebar grid can be substituted for the wire mesh in most cases. Place the #4 bars in the foundation at 18" center to center each way.

Specifications for 48' Diameter Bin

Ring	B	N	Outside Radius	Sq. Ft. Mesh	Optional 18" x 18" Grid (ft.)	Length #6 Bar (ft.)	Total Cu.Yds. Concrete
6	1' 5"	2	24' 8"	3400	2300	400	44
7, 8	2' 3"	3	24' 11"	3400	2300	800	49
9	3' 3"	4'	25' 2"	3400	2300	1100	55
10	4' 5"	5	25' 8"	3400	2300	1400	63

4. Foundations

NOTE: All foundation specifications are recommendations only. Due to many variable conditions in actual installation, the manufacturer assumes no liability for results arising from the use of such recommendations.

Specifications for 48' Diameter Bin

Ring	B	C	D	M	N	P (Center to Center)	#4 Bar (ft.)	#5 Bar (ft.)	Cu. Yds. Concrete
6	1'-6"	24'-7"	24'-8"	5 #4's	2 #5's	#5 at 14" c/c	5600	600	68
7, 8	2'-3"	24'-7"	25'-0"	5 #4's	3 #5's	#5 at 14" c/c	5600	800	72
9	3'-2"	24'-7"	25'-5"	6 #4's	3 #5's	#5 at 14" c/c	5800	900	77
10	4'-2"	24'-7"	25'-10"	6 #4's	4 #5's	#5 at 14" c/c	5800	1200	84

Base Angle Installation

A bolt on the base angle is standard on 8 gauge unstiffened base ring sheets and all Farm-Com base rings. Install base angle on 8 gauge base ring as shown in [Figure 4J](#) below.

- Once the door frame has been placed and secured, continue adding necessary side wall ring(s).
- To the lower edge of the 8 gauge bottom ring, attach the base angle. Bolt on the base angle where applicable. Before lowering the bin, apply mastic sealer to the entire underneath side of the base angle. (See [Figure 4J](#).)
- Next, lower the bin onto the foundation and check for an adequate seal.
- Sealing the base of the bin after final construction is done by various methods and materials. However, provisions should be made to seal the base of the bin to prevent moisture from coming into the bin.

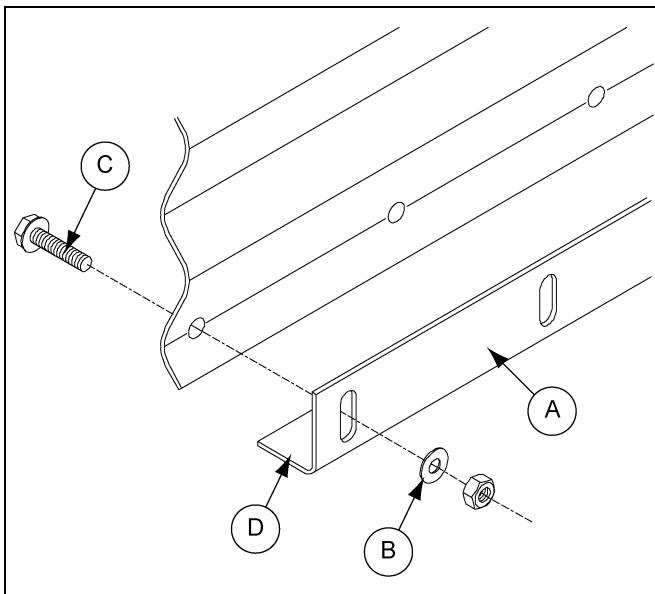

Figure 4J

Ref #	Part #	Description
A	B-6753	Base Angle
B	S-248	Washer
C	S-7483	5/16" x 1-1/4" Bin Bolt
D		Mastic Sealer Underneath (Optional, not Provided with Bin)

Bolt and Nut Pairings

This chart lists the correct nut to use with each size of bolt.

Nut Part #	Nut Size	Type	Hex or Flanged	Bolt Size	Bolt Part #
S-396	5/16"	YDP	Hex	5/16" x 1"	S-10260
				5/16" x 1-1/4"	S-7483
S-3611	5/16"	YDP	Flanged	5/16" x 1"	S-10260
				5/16" x 1-1/4"	S-7483
S-456	3/8"	YDP	Hex	3/8" x 1"	S-7487
S-9426	3/8"	JS	Flanged	3/8" x 1"	S-7485

Hardware for Sidewall Sheets on 4" Corrugation Bins 12' to 48' Diameter

Refer to chart for hardware requirements for unstiffened sidewall sheet connections on bins 12' to 48' diameter.

Gauge	Horizontal Seam Bolt Size (Quantity)	Vertical Seam Bolt Size (Quantity)	Overlap Seam Bolt Size (Quantity)
20	5/16" x 1" (10)	5/16" x 1" (21)	5/16" x 1" (2)
19	5/16" x 1" (10)	5/16" x 1" (21)	5/16" x 1" (2)
18	5/16" x 1" (10)	5/16" x 1" (21)	5/16" x 1" (2)
17	5/16" x 1" (10)	5/16" x 1" (21)	5/16" x 1" (2)
16	5/16" x 1" (10)	5/16" x 1" (21)	5/16" x 1" (2)
15	5/16" x 1" (10)	5/16" x 1" (21)	5/16" x 1" (2)
14	5/16" x 1" (22)	5/16" x 1" (42)	5/16" x 1" (2)
13	5/16" x 1" (22)	5/16" x 1" (42)	5/16" x 1" (2)
12	3/8" x 1" (22)	3/8" x 1" (42)	3/8" x 1" (2)
11	3/8" x 1" (22)	3/8" x 1" (42)	3/8" x 1" (2)
10	3/8" x 1" (22)	3/8" x 1" (42)	3/8" x 1" (2)
9	3/8" x 1" (22)	3/8" x 1" (42)	3/8" x 1" (2)
8	3/8" x 1" (22)	3/8" x 1" (42)	3/8" x 1" (2)

NOTE: Use 5/16" bolts and nuts while joining 13 to 12 gauge on horizontal seams.

5. Hardware Requirements

Bolt Torque Specifications

The specification torque table *below* will help the installer determine how tight a specific bolt must be. A bolt that has been over tightened can be just as dangerous as one that has not been tightened enough.

IMPORTANT: Bolts should not be tightened in excess of the torque specifications chart listed *below*.

Bolt	Minimum Torque				Maximum Torque			
	Sealing Joints (Joints with Sealing Washers)		Structural Joints (Joints without any Sealing Washers)		Sealing Joints (Joints with Sealing Washers)		Structural Joints (Joints without any Sealing washers)	
	ft./lbs.	N-m	ft./lbs.	N-m	ft./lbs.	N-m	ft./lbs.	N-m
5/16"-18 JS Grade 8 with Seal	20	27	-	-	25	34	-	-
3/8"-16 JS Grade 8 with Seal	30	41	-	-	35	47	-	-
7/16"-14 JS Grade 8 with Seal	50	68	-	-	60	81	-	-
3/8"-16 YDP Grade 8 Flanged	-	-	40	54	-	-	45	61
7/16"-14 YDP Grade 8 Flanged	-	-	65	88	-	-	72	97
1/2"-13 YDP Grade 8 Flanged	-	-	100	135	-	-	110	149

Identifying Bolt Grades

Bolts are identified by grade (or hardness), the grade can be identified by the markings on the head of the bolt. These markings will be in the form of slash marks and patterns. Use the following as a guide to determine the correct bolt grade.



Under no condition shall any other bolts be substituted for those supplied by GSI.

Grade 2 Bolts

Grade 2 bolts are designated with a plain head and are not used in GSI grain bins.

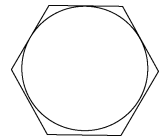

Grade 5 Bolts

Grade 5 bolts are designated by three (3) slash marks on the head. All 5/16" diameter bolts are to be grade 5 or higher.

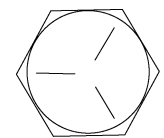

Grade 8 Bolts

Grade 8 bolts are designated by six (6) slash marks evenly spaced out around the head of the bolt. All 3/8", 7/16" and 1/2" diameter bolts are to be grade 8 or grade 8.2.

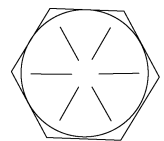

Grade 8.2 Bolts

Grade 8.2 bolts are designated by six (6) slash marks on the head in a sunrise pattern. All 3/8", 7/16" and 1/2" diameter bolts are to be grade 8 or grade 8.2.

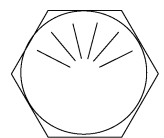

NOTE: Refer to 4.00" commercial tank bolting requirements for complete bolt usage.

Bolt Identification

Use the following information to identify the bolts and where each must be used during installation.

Bolt (S-10260)

An S-10260 is a 5/16" x 1" JS bolt that is pre-assembled with a sealing washer.

Bolt (S-10260) is used in the following locations:

1. Use to connect horizontal, vertical and overlap seams on 14 gauge to 20 gauge sidewall connections.
2. Use to connect roof panels together where they overlap.
3. The color of the bucket lid is lime green.
4. Use to connect eave clip to sidewall sheet on roofs that are non z-tek 48' diameter and smaller.
5. Use to attach roof panels to flashing on all bins that are 48' diameter and smaller.

A	1.300" (3.30 cm)	C	Grade 8
B	1.000" (2.54 cm)	D	Grade 8.2

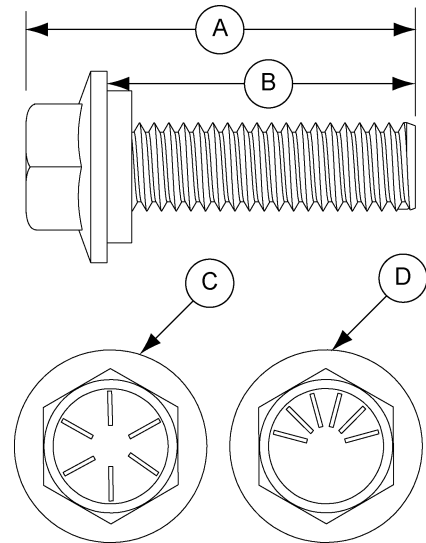

Bolt (S-7483)

An S-7483 is a 5/16" x 1-1/4" JS bolt pre-assembled with a sealing washer.

Bolt (S-7483) is used in the following locations:

1. Use in base angle to sidewall connection.
2. Use in accessories.
3. The color of the bucket lid is black.
4. Used in flashing to sidewall connections

A	1.437" (3.64 cm)
B	1.250" (3.17 cm)
C	Grade 8
D	Grade 8.2

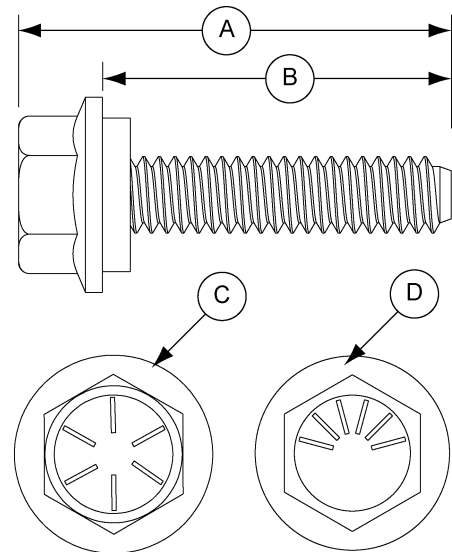

5. Hardware Requirements

Bolt (S-7485)

An S-7485 is a 3/8" x 1" JS hex bolt with flanged head and without a sealing washer.

Bolt (S-7485) is used in the following locations:

1. Use in 48' farm roof only.
2. The color of bucket lid is light green.

A	1.350" (3.43 cm)
B	1.000" (2.54 cm)
C	Grade 8
D	Grade 8.2

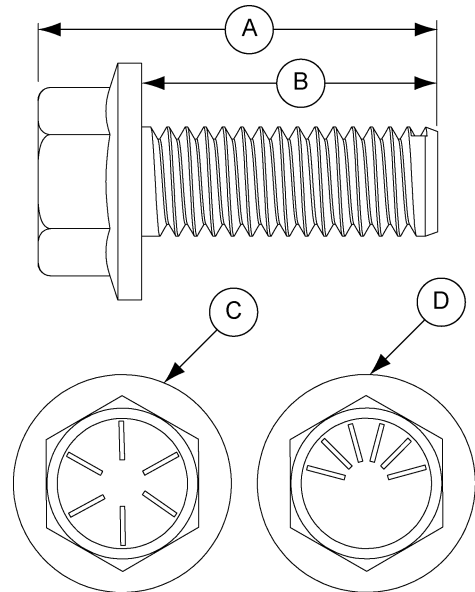

Bolt (S-7487)

An S-7487 is a 3/8" x 1" JS bolt that is pre-assembled with a sealing washer.

Bolt (S-7487) is used in the following locations:





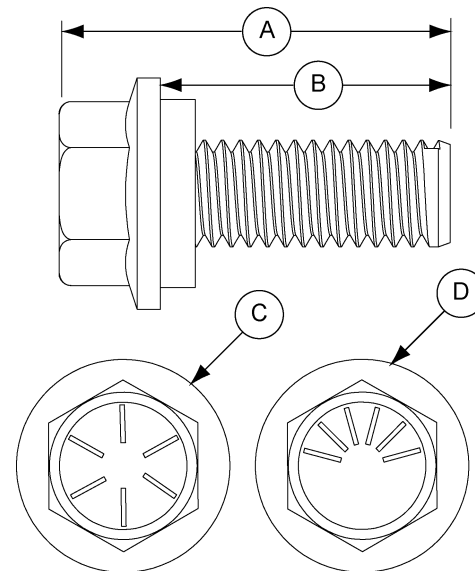

1. Use in all sidewall connections for 12 gauge through 8 gauge sidewall to sidewall sheets.
2. The color of bucket lid is light grey.

A	1.350" (3.43 cm)
B	1.000" (2.54 cm)
C	Grade 8
D	Grade 8.2



Color Chart for Bin Hardware Bucket Lids

For ease of identification, hardware is separated and identified by buckets with color coded lids. Use the following chart to help identify the correct hardware.

Part #	Color	Bucket Count	Lid Color	Description
S-10260	<i>Lime Green</i>	1250		5/16" x 1" Bolt pre-assembled with sealing washer
S-7483	<i>Black</i>	1000		5/16" x 1-1/4" Bolt pre-assembled with sealing washer
S-396	<i>Red</i>	5000		5/16" Hex nut
S-3611	<i>Gold</i>	NA		5/16" Flange nut
S-7487	<i>Grey</i>	850		3/8" x 1" Bolt pre-assembled with sealing washer
S-7485	<i>Light Green</i>	850		3/8" x 1" Flanged bolt without sealing washer
S-9426	<i>Dark Purple</i>	2500		3/8" Hex flanged nut

6. Assembling Sidewall Sheets

Guidelines for Constructing Sidewall Sheets

1. Before bolting the sidewall sheets together, check for the proper gauge of steel for the first ring. Higher gauge numbers denote the thinner materials. (For example, 20 gauge material is thinner than 14 gauge.)
2. In erecting most grain bins, the thinnest material usually goes on top, therefore the first sidewall ring you assemble will be the top ring of the bin.
3. Check the various gauges of the bin with the color code chart and begin building accordingly.
4. Assemble the top ring first.

NOTE: *The decal is orientated correctly.*

Color Codes for Sidewall Gauge Identification

Use this chart to interpret the color code painted on the corners of the sidewall sheets.

Color Codes for Sidewall Gauges

Sidewall Gauge	Color Code
20	Red
19	Black and Yellow
18	Orange
17	Light Blue and Pink
16	Blue
15	Red and Brown
14	Green
13	Blue and Yellow
12	Black
11	Pink
10	Light Blue
9	Blue and Orange
8	Yellow and Purple

Orientation Detail for Top Sidewall Sheets

To avoid the misalignment of the holes, it is necessary to use the correct orientation of the sidewall sheet during installation. (See [Figure 6A.](#))

NOTE: Always assemble the top sidewall sheets with the orientation shown.

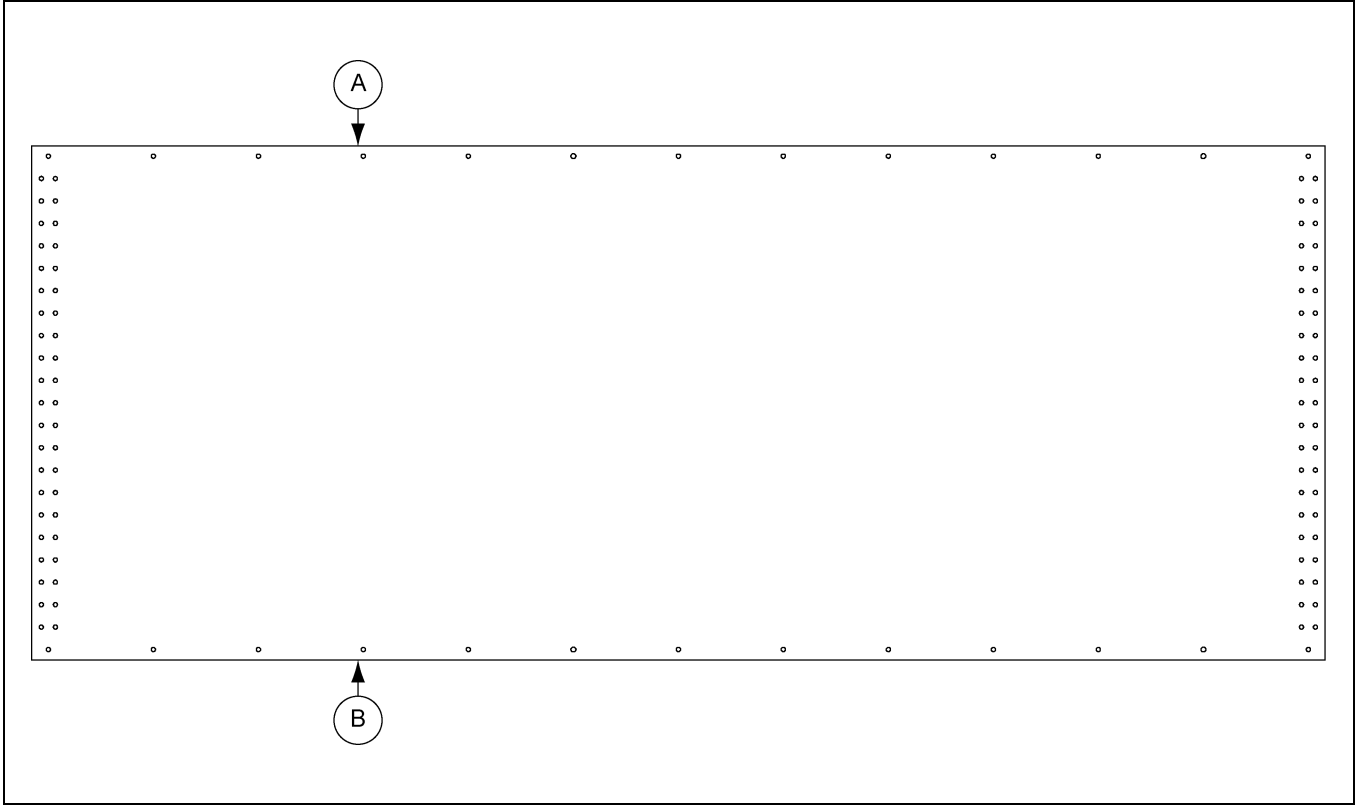

Figure 6A Top Sidewall Sheet Orientation (Viewed from Outside of the Bin)

Ref #	Description
A	Top of the Top Sidewall Sheet
B	Bottom of the Top Sidewall Sheet

6. Assembling Sidewall Sheets

Caulking and Bolting Detail for Standard Sidewall Sheets

To keep out moisture from overlapping the sheets, it is necessary to apply caulk to each sheet prior to installing. (See [Figure 6B.](#))

NOTE: Always assemble the sidewall sheets with the overlap in the same direction.

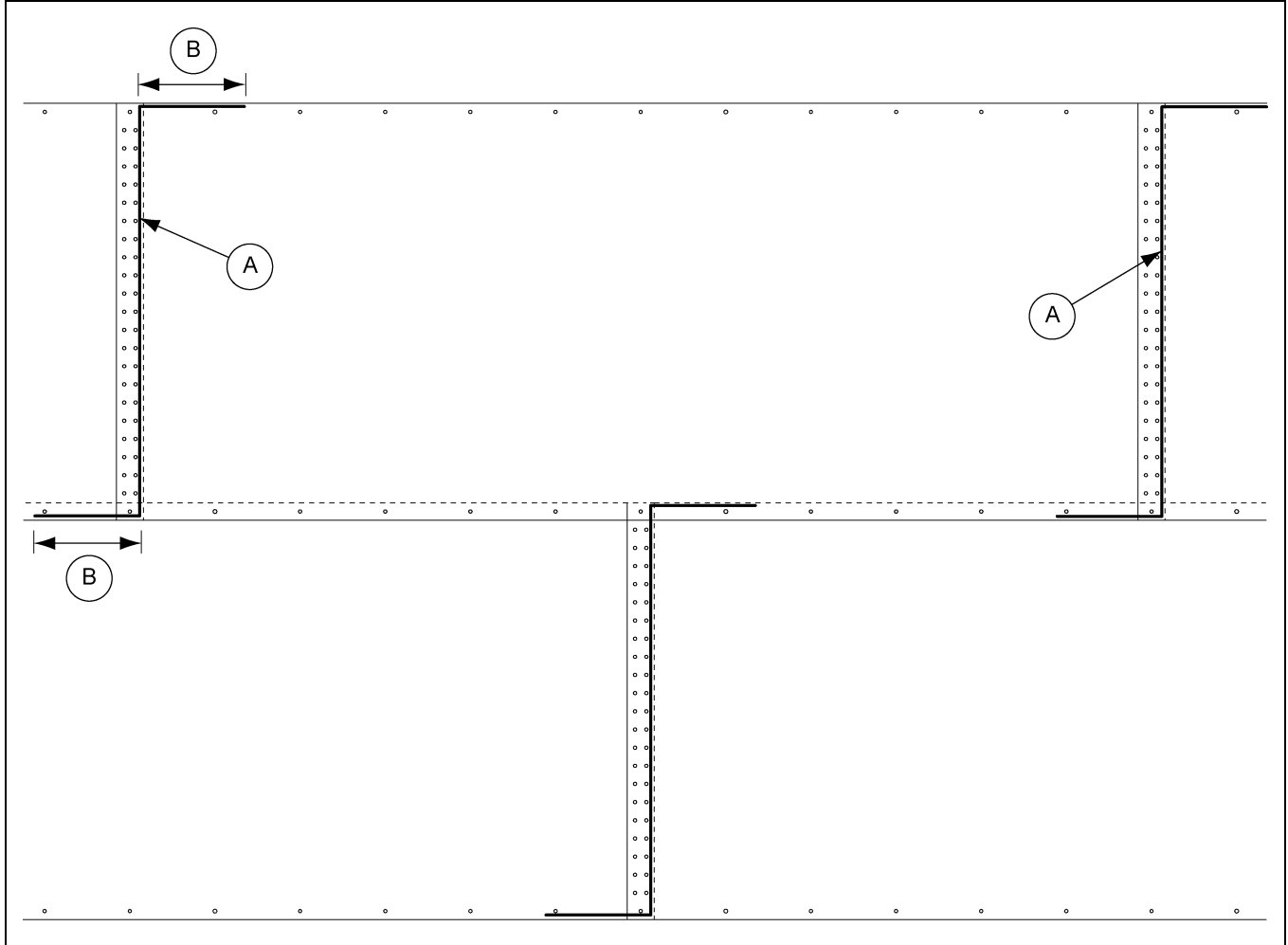

Figure 6B Standard Sidewall Sheets as Viewed from the Outside of the Bin

Ref #	Description
A	Vertical Strip of Caulk
B	10" (25.4 cm) Horizontal Strip of Caulk

Caulking and Bolting Detail for Standard Sidewall Sheets (Continued)

1. Apply a strip of caulk near the outside edge of the outer sheet and between the outer two (2) rows of bolts (A), then apply a strip of caulk 10" (25.4 cm) long along the horizontal seams (B), as shown in [Figure 6C](#).

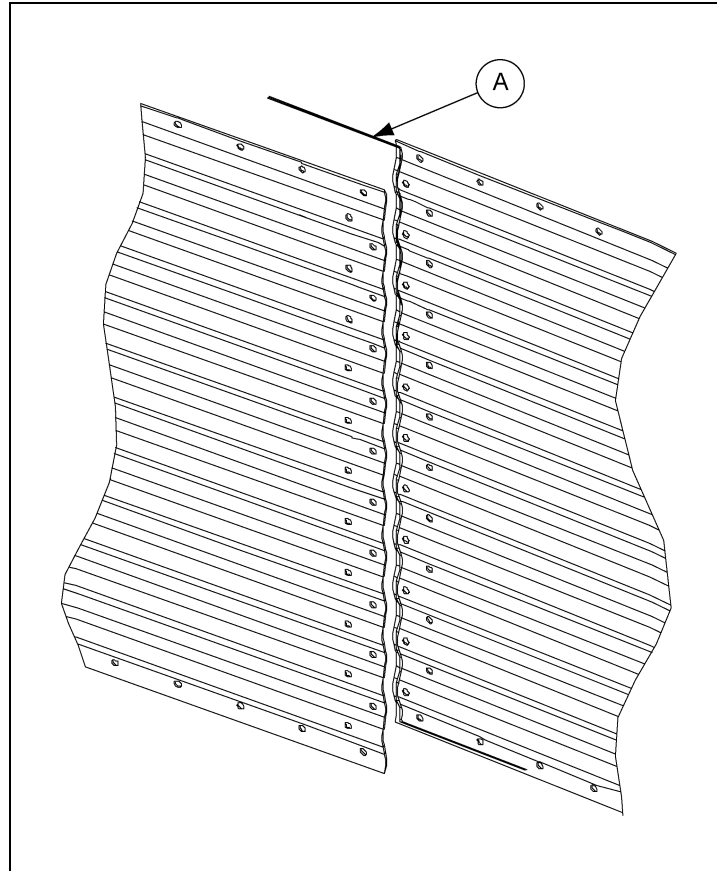

Figure 6C Caulking and Bolting Details (Viewed from Inside of the Bin)

Ref #	Description
A	Strip of Caulk

2. Start assembling the sidewall sheets end to end (overlapping the same way throughout), until the ring is completed.
3. Install the correct size bin bolts with the bolt head and its neoprene washer to the outside and the nut on the inside of the bin.

NOTE: Do not tighten bolts until all the sheets are assembled and form a complete ring.

4. Tighten the bolts in sequence, starting from the center to the edge in both directions. This allows the sidewall sheets to draw-up evenly.

NOTE: Tighten from the nut side.

7. Door Assembly

Door Placement

Consider the location of the door and other accessories before starting the bin. Proper placement of lifting jacks in relationship to the anchor bolts could make a difference on odd or even ring bins. (See Figure 7A.)

NOTE: The walk-through diameter door must be centered between two (2) anchor bolts. The sidewall sheets are staggered 1/3 from end to end.

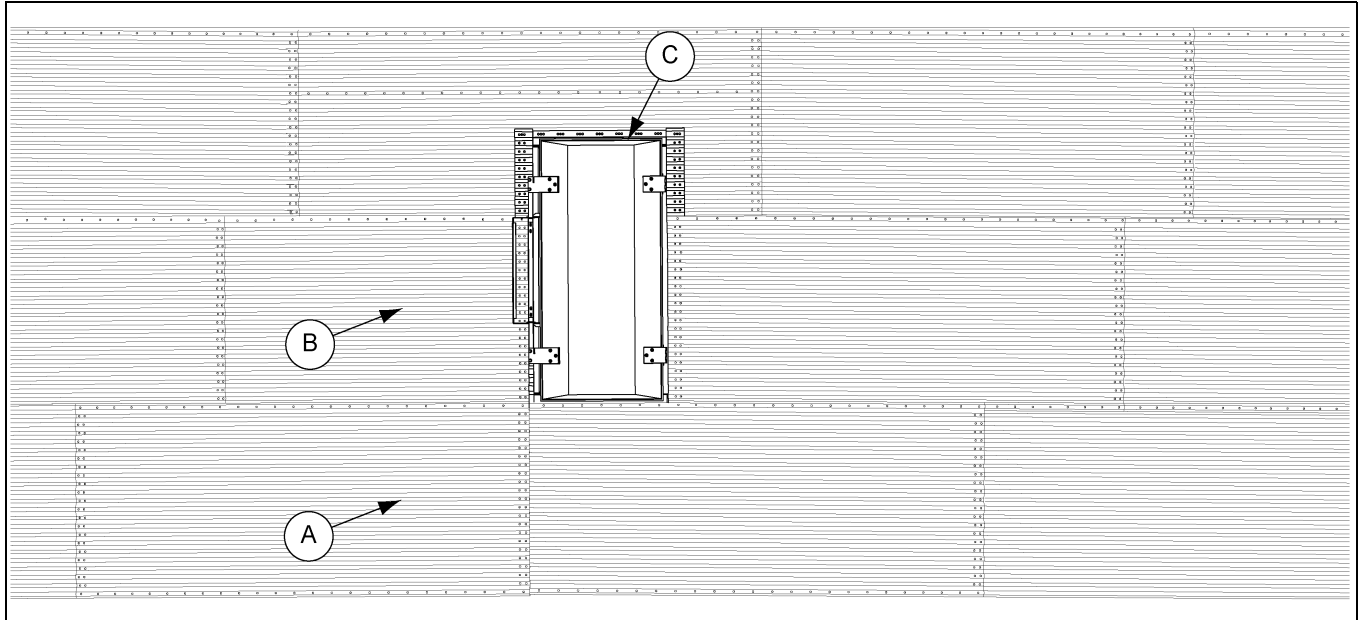

Figure 7A 2 Ring Door (As Viewed from the Outside of the Bin)

Ref #	Description
A	First Ring (From Bottom of the Bin)
B	Second Ring (From Bottom of the Bin)
C	Door Assembly

2 Ring Door Installation

Before You Begin

Before starting to install, make sure the correct door has been received. Note that one ring doors are standard with some sizes of bins/silos. Refer to round access door installation instructions.

General Information

1. The commercial two ring door is installed in the bottom two rings.
2. The door should normally be placed in line with the conveyor. An intermediate discharge well should be located near the wall to clear grain from the area of the access door (as with any access door).
3. The door should be located either between two stiffeners on a commercial tank or between two anchor bolts on a farm tank.

4.00" Corrugation	
WD-6246	48'-Maximum height of 8 rings
WD-6244	48'-Bins/Silo - 9 rings
WD-6248	

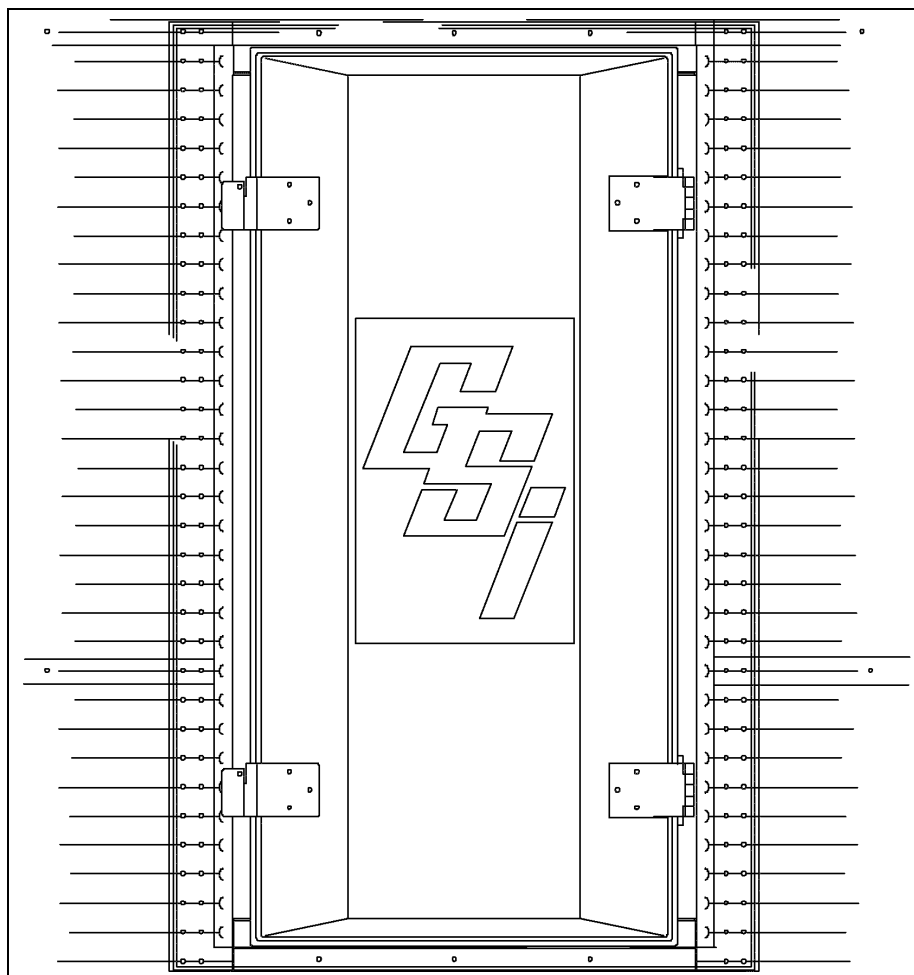

Figure 7B 2 Ring Door Installed

7. Door Assembly

2 Ring Door Installation Instructions

NOTE: Refer to PNEG-301 for detailed assembly instructions.

1. Remove the inner door panels (Q, R and S) and outer door cover (A) from the door assembly.

NOTE: Place the top of the door frame to the inside of the sidewall and the bottom of the door frame to the outside of the sidewall. Therefore, depending upon the location and overlap, caulk will be applied on either the inside or the outside of the door flanges.

2. Apply two rows of rope caulk around all four door flanges: On vertical flanges, one row of caulk should be applied between the two vertical rows of bolts and the other row of caulk should be applied between the door frame and the first row of vertical bolts. On the horizontal flanges, a row of caulk should be applied on each side of the row of bolts.
3. Align the holes in the door frame with the holes in the sidewall opening. Insert a bolt at the four corners of door frame and sidewall, but do not tighten until completing [Step 4](#).
4. Re-install the inner door panels (Q, R and S) at original locations. Close latch bars (J) to lock panels in place. Make sure that panels are fully seated over all bearing pins (O). Install the inner panel hinge (H, I and J) assemblies as per illustration instructions with hinges.

NOTE: Do not distort door frame with use of alignment or drift punches - if necessary, drill or ream holes to insert bolts in door frame. Now tighten frame bolts starting at center and working toward top and bottom on each side.

5. Keep inner panels (Q, R and S) latched and loosen all bearing pin bolts. Re-tighten all bearing pinbolts. This makes loading on pins uniform for easier operation of panels.
6. If some latch bars are loose or require excessive force to lock, loosen hex socket cap screws and adjust in or out until latch bars operate smoothly. Check that the panels are fully seated over all bearing pins.
7. Re-install outer door cover (A). Adjust outer door hinges (C) and latches (B) as required.
8. Assemble door hold back (V and W) as shown. Open door cover (A) until it approaches the bin wall. Hook the retaining bracket over lower latch mount and position the door hold back bracket against bin wall in a valley. Drill a 3/8" hole through the bin wall and bolt the door hold back bracket to the bin. If needed, install the door hold back extension to door hold back bracket.

NOTE: 48' Diameter bins up to 8 rings.

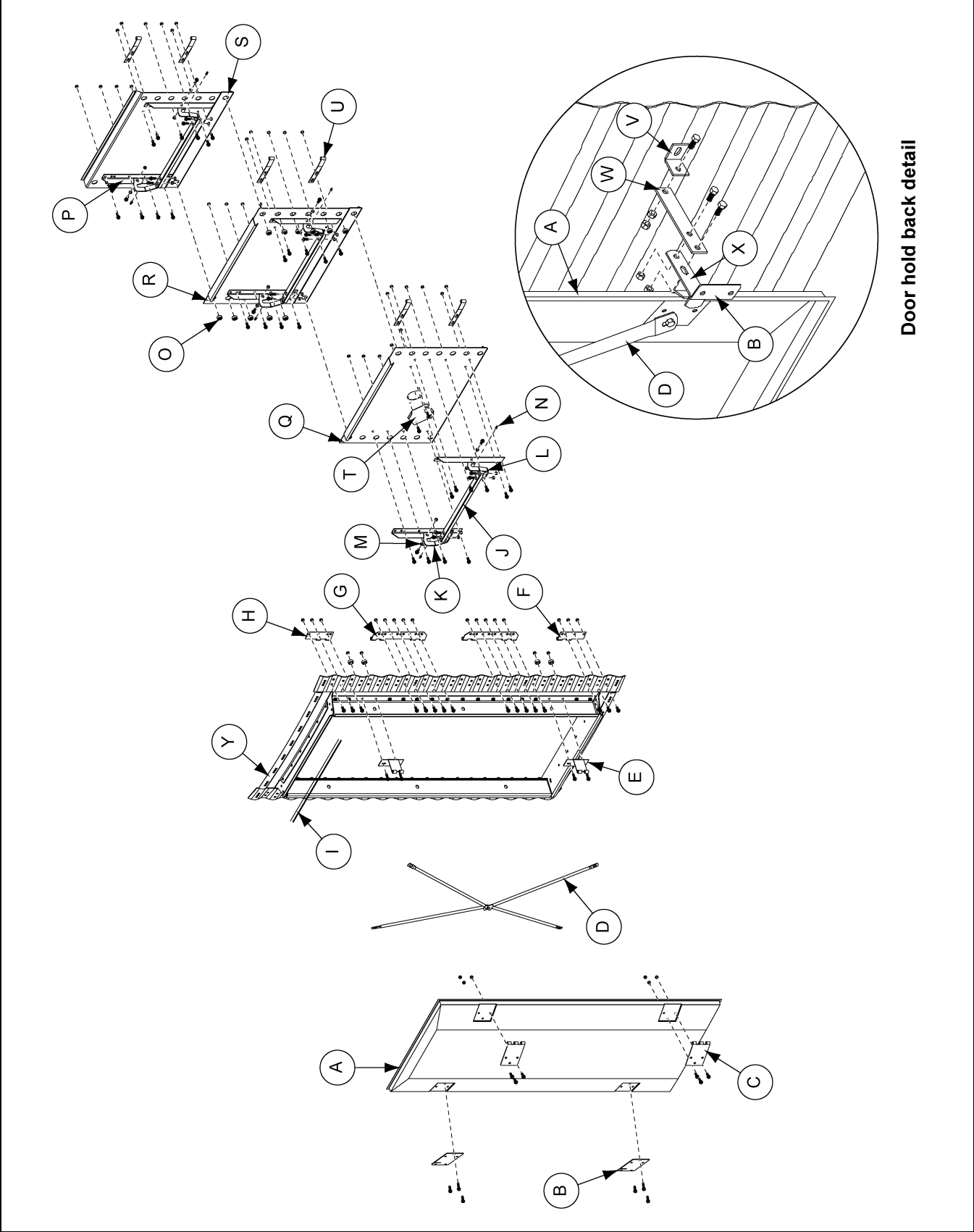

Door hold back detail

Figure 7C Standard 2 Ring Door

7. Door Assembly

Ref #	Part #	Description	Qty
A	WD-039	Outer Door Cover	1
B	WD-6283	Outer Cover Latch Bracket	2
C	WD-225	Outer Cover Hinge Bracket	2
D	WD-035	Door Cover Brace Section	4
E	WD-6066	Outer Cover Hinge Base	2
F	WD-6055	Bottom Inner Door Hinge	1
G	WD-6056	Middle Inner Door Hinge	2
H	WD-6054	Top Inner Door Hinge	1
I	S-4380	Rubber Trim Seal Strip	2-1/4"
J	WD-6039	Latch Bar	3
K	WD-6037	Inner Panel Latch - Right Hand	3
L	WD-6038	Inner Panel Latch - Left Hand	3
M	WD-6040	Latch Bushing	6
N	S-8648	1/2" x 1-1/2" Hex Socket Cap Screw	6
O	WD-6079	Long Bearing Pin	38
P	WD-6125	Inner Panel Reinforcing Angle	6
Q	WD-6128	Bottom Inner Door Panel	1
R	WD-6127	Middle Inner Door Panel	1
S	WD-6126	Top Inner Door Panel	1
T	WD-6028	Bottom Inner Door Port Hole Cover	1
U	WD-6053	Inner Door Hinge Strap	6
V	WD-1302	Door Hold Back Bracket	1
W	WD-6110	Door Hold Back Extension	1
X	WD-033	Door Retainer	3
Y		Door Frame Assembly	

NOTE: 48' Diameter bins 9 rings (WD-6244 and WD-6248).

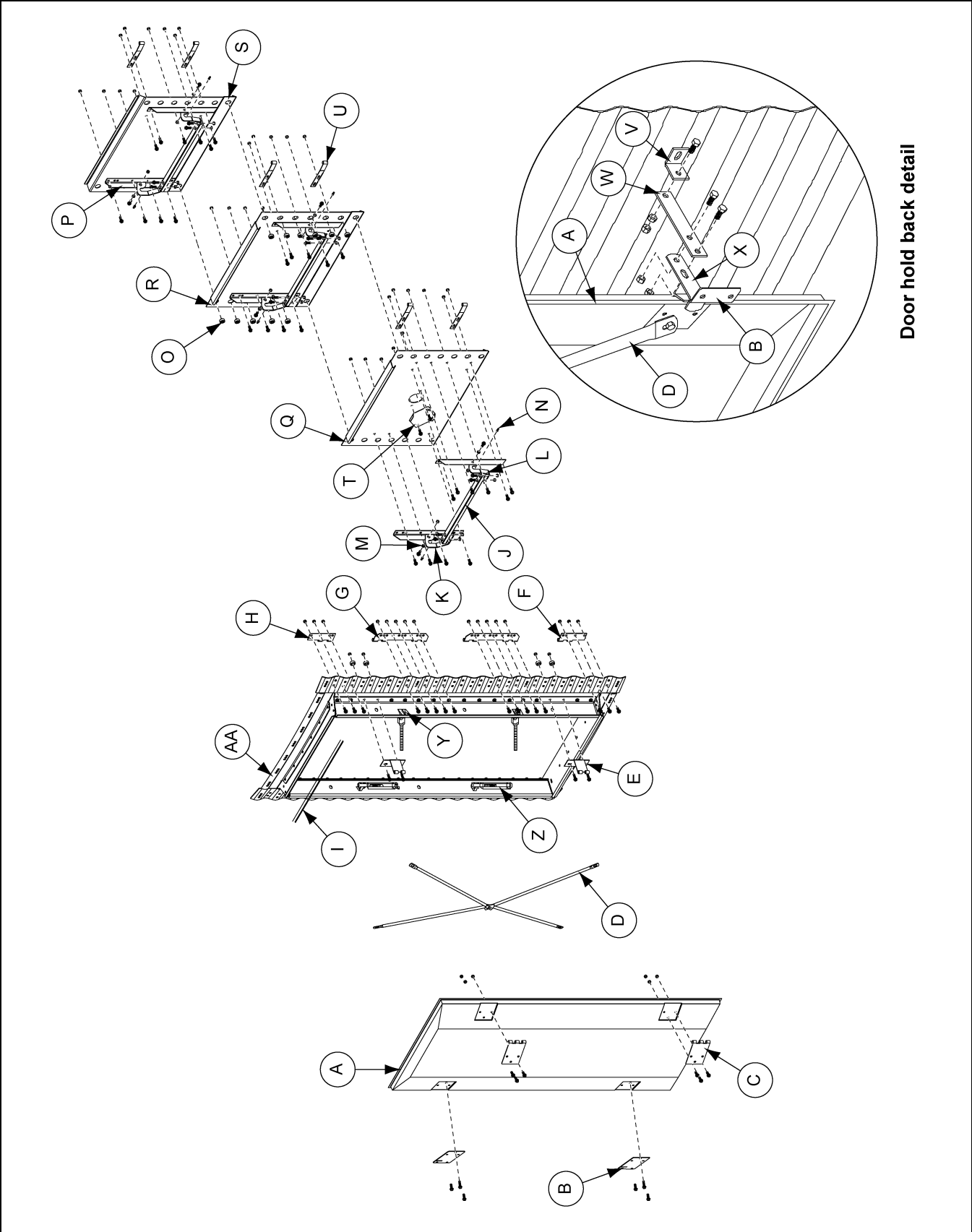

Door hold back detail

Figure 7D Heavy 2 Ring Door

7. Door Assembly

Ref #	Part #	Description	Qty
A	WD-039	Outer Door Cover	1
B	WD-6283	Outer Cover Latch Bracket	2
C	WD-225	Outer Cover Hinge Bracket	2
D	WD-035	Door Cover Brace Section	4
E	WD-6066	Outer Cover Hinge Base	2
F	WD-6055	Bottom Inner Door Hinge	1
G	WD-6056	Middle Inner Door Hinge	2
H	WD-6054	Top Inner Door Hinge	1
I	S-4380	Rubber Trim Seal Strip	2-1/4"
J	WD-6039	Latch Bar	3
K	WD-6037	Inner Panel Latch - Right Hand	3
L	WD-6038	Inner Panel Latch - Left Hand	3
M	WD-6040	Latch Bushing	6
N	S-8648	1/2" x 1-1/2" Hex Socket Cap Screw	6
O	WD-6079	Long Bearing Pin	38
P	WD-6125	Inner Panel Reinforcing Angle	6
Q	WD-6140	Bottom Inner Door Panel	1
R	WD-6141	Middle Inner Door Panel	1
S	WD-6139	Top Inner Door Panel	1
T	WD-6028	Bottom Inner Door Port Hole Cover	1
U	WD-6053	Inner Door Hinge Strap	6
V	WD-1302	Door Hold Back Bracket	1
W	WD-6110	Door Hold Back Extension	1
X	WD-033	Door Retainer	3
Y	WD-6147	Turnbuckle Latch Weldment	4
Z	D32-0003	Turnbuckle 5/8" x 9"	2
AA		Special Heavy Door Frame Assembly	

Two-Ring Door Latch Assembly

1. Install outer door latch assembly (WD-6289) to the door frame lining up to the door latch mount (L) with the 6th bolt from the top and door latch mount (K) with the 6th bolt from the bottom.
2. Install the door latch rod (M) to the door latch mount (F). (See Figure 7E.)

NOTE: If replacing old style latch, remove outer cover latch bracket and replace with outer door latch rod mount (F).

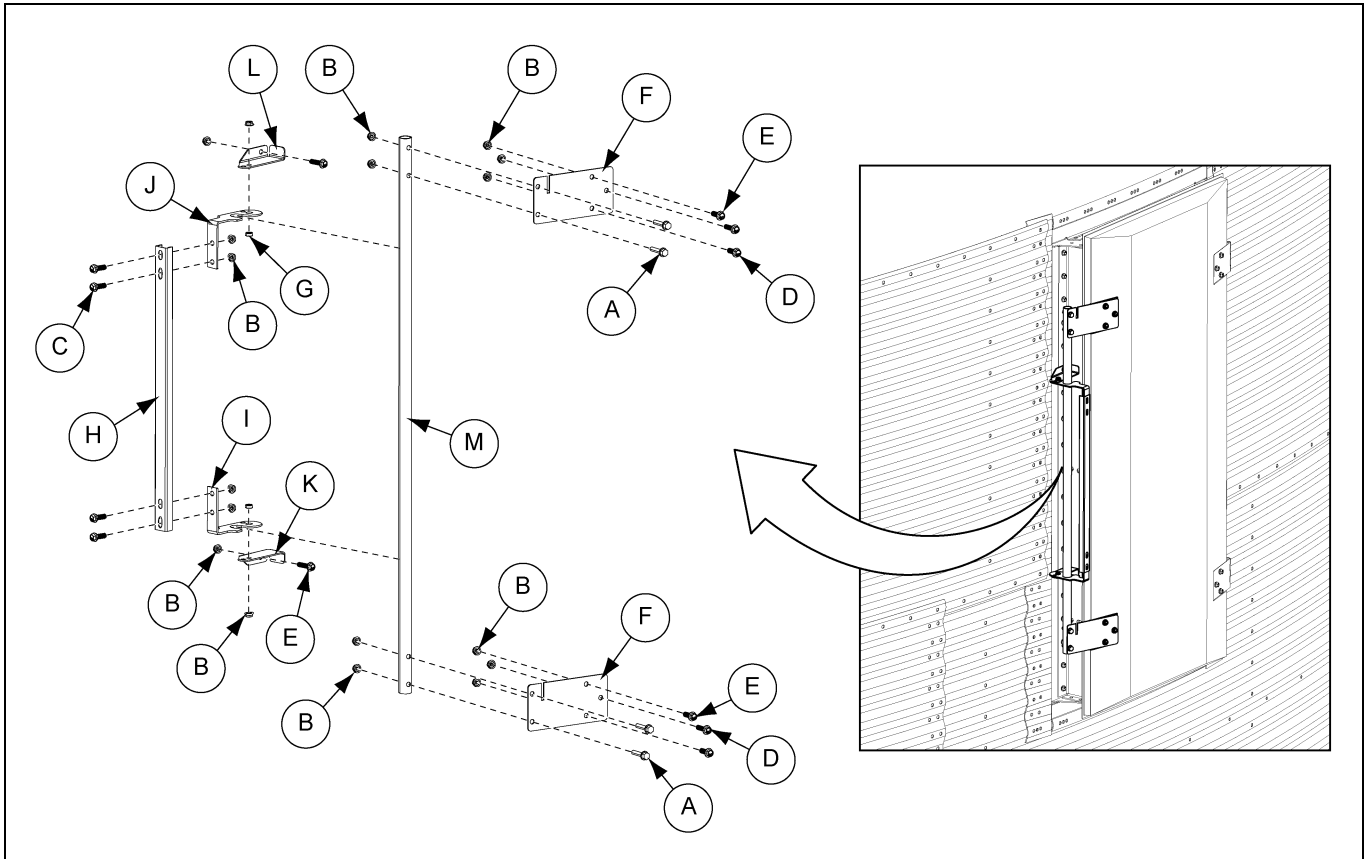

Figure 7E Two Ring Door Latch

Ref #	Part #	Description	Qty
A	S-10185	5/16" x 1-1/2" Flange Bolt	4
B	S-10268	5/16" Flange Nut	10
C	S-4302	5/16" x 3/4" Truss Bolt	6
D	S-10260	5/16" x 1" Flange Bolt with Sealing Washer	4
E	S-7483	5/16" x 1-1/4" Flange Bolt	4
F	WD-6283	Door Latch Rod Mount	2
G	WD-6040	Latch Bushing	1
H	WD-6039	Latch Bar	1
I	WD-6278	Bottom Door Latch	1
J	WD-6279	Top Door Latch	1
K	WD-6280	Bottom Door Latch Mount	1
L	WD-6281	Top Door Latch Mount	1
M	WD-6282	Door Latch Rod	1

7. Door Assembly

Options for 2 Ring Door - Bin Step

1. Attach the left and right sides (B and C) to the sides of the bin door step (D) using bolts (E) and nuts (G).
2. Center the assembled step under the bin door and use it as a template to field drill the holes (F) in the sidewall sheet on the ridges of the corrugation.
3. Install the bin step (A) to the sidewall sheet using bolts (E) and nuts (G). (See Figure 7F.)

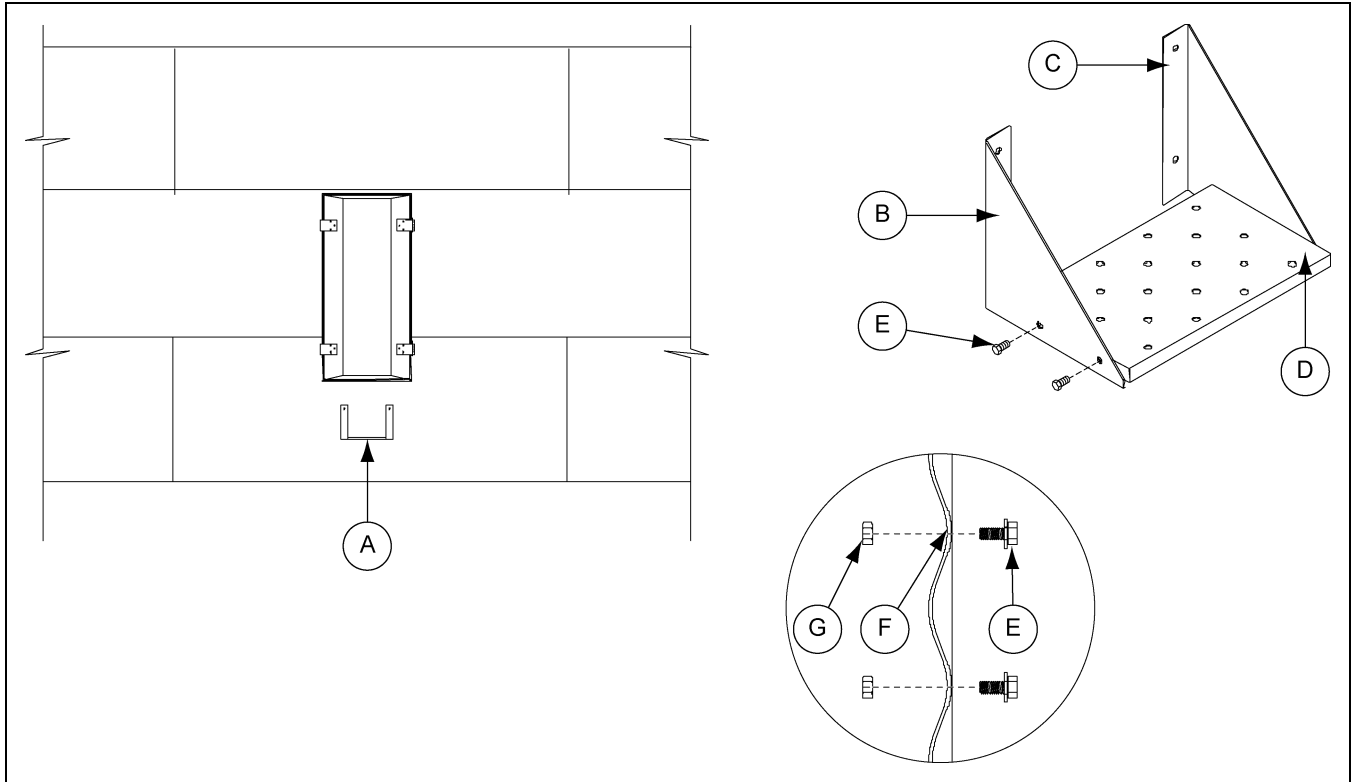

Figure 7F Bin Step

Ref #	Description
A	Center Bin Step Under Door
B	Left Side (WD-041-1)
C	Right Side (WD-041-2)
D	Bin Door Step (WD-1984)
E	5/16" x 1" Hex Head Bolt
F	Field drill holes in sidewall sheet on the ridge of corrugation.
G	5/16" Nut

Installing the Roof Rafter Bracket to the Sidewall

The roof rafter bracket is the vertical member which supports the rafter. It is installed to the inside perimeter of the sidewall sheet.

What You Should Know

Field drill $3/8$ " hole 4" below the center of horizontal seam holes over $9-3/8$ " from right side first horizontal seam hole. Drill three (3) more holes spaced 8" down each starting from first field drilled hole. See the details in [Figure 8A](#).

NOTE: Do not tighten the nuts (B) until all hardware has been installed attaching the rafter bracket, to the sidewall.

1. From the inside perimeter of the sidewall, place the bolt (A) to attach the rafter bracket (C) through the hole located approximately 4" down from the top of the sidewall sheet.

NOTE: Install the bolts from the inside to the outside of the bin, passing through the rafter bracket, corrugation spacer, sealing washer, sidewall sheet and flange nut.

NOTE: Make sure to install the bolts through every second hole from the top of the rafter bracket.

2. On the inside perimeter, install a sealing washer (E), corrugation spacer (D) and rafter bracket (C).
3. Tighten the hardware to the recommended torque specifications. See bolt torque specifications on [Page 30](#).

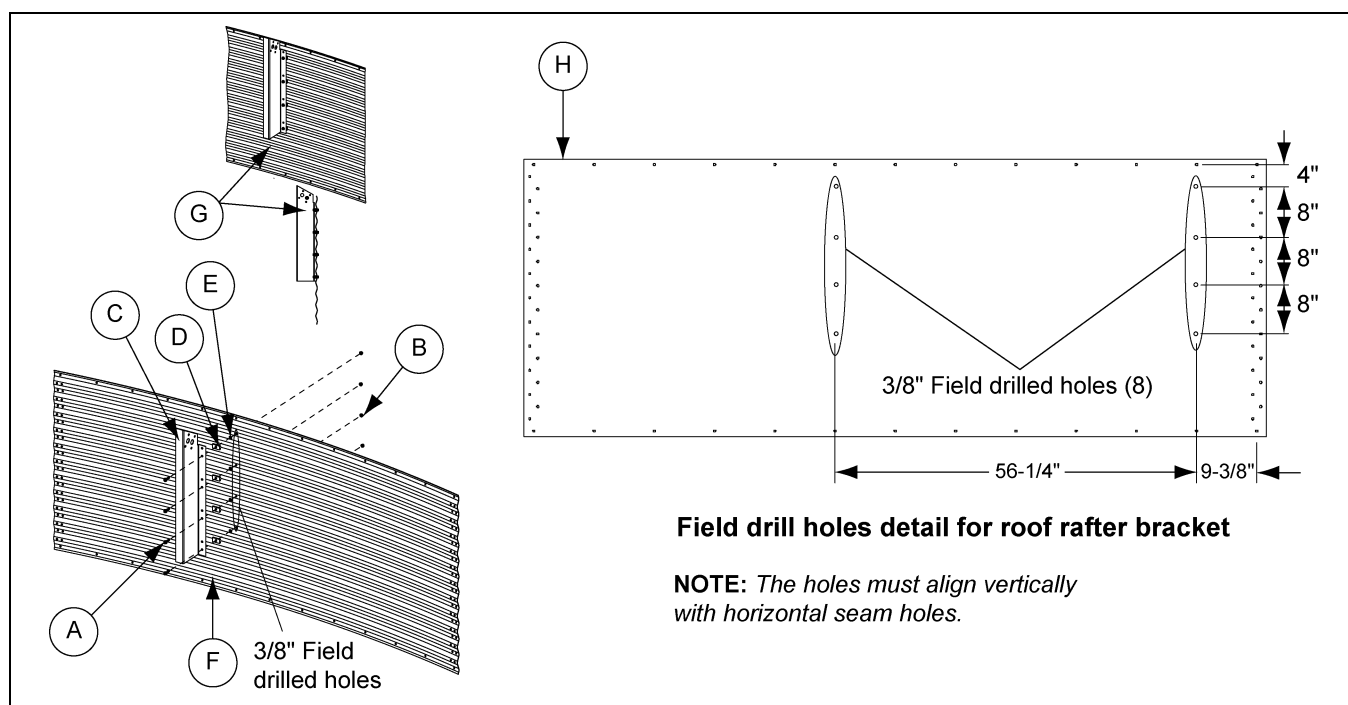

Figure 8A Installing the Roof Rafter Bracket to the Sidewall

Ref #	Part #	Description
A	S-7488	$3/8$ " x $1-1/2$ " Flange Bolt
B	S-9426	$3/8$ " Nut
C	CTR-1364	Roof Rafter Bracket
D	S-7041	Corrugation Spacer

Ref #	Part #	Description
E	S-3558	Sealing Washer
F		Sidewall Sheet
G		Assembled View
H		Top of Sidewall Sheet

8. Roof Assembly

Installing the Eave Clip and Intermediate Eave Angle to the Sidewall Sheet

The eave clips and intermediate eave angles are installed onto the sidewall sheet to assemble the roof panels.

1. Install the eave clips (B) to the sidewall sheet (E) with flange bolts (C) and flange nuts (D).

NOTE: Make sure to install the eave clips (B) to the inside of the sidewall sheet.

2. Install the intermediate eave angle (A) to the sidewall sheet (E) with flange bolts (C) and flange nuts (D) between the two (2) eave clips (B).

NOTE: Make sure to install the intermediate eave angle (A) to the outside of the sidewall sheet (E).

3. Repeat the process to continue installing the remaining eave clips (B) and intermediate eave angles (A).
4. Tighten the hardware to the recommended torque specifications. See bolt torque specifications on [Page 30](#).

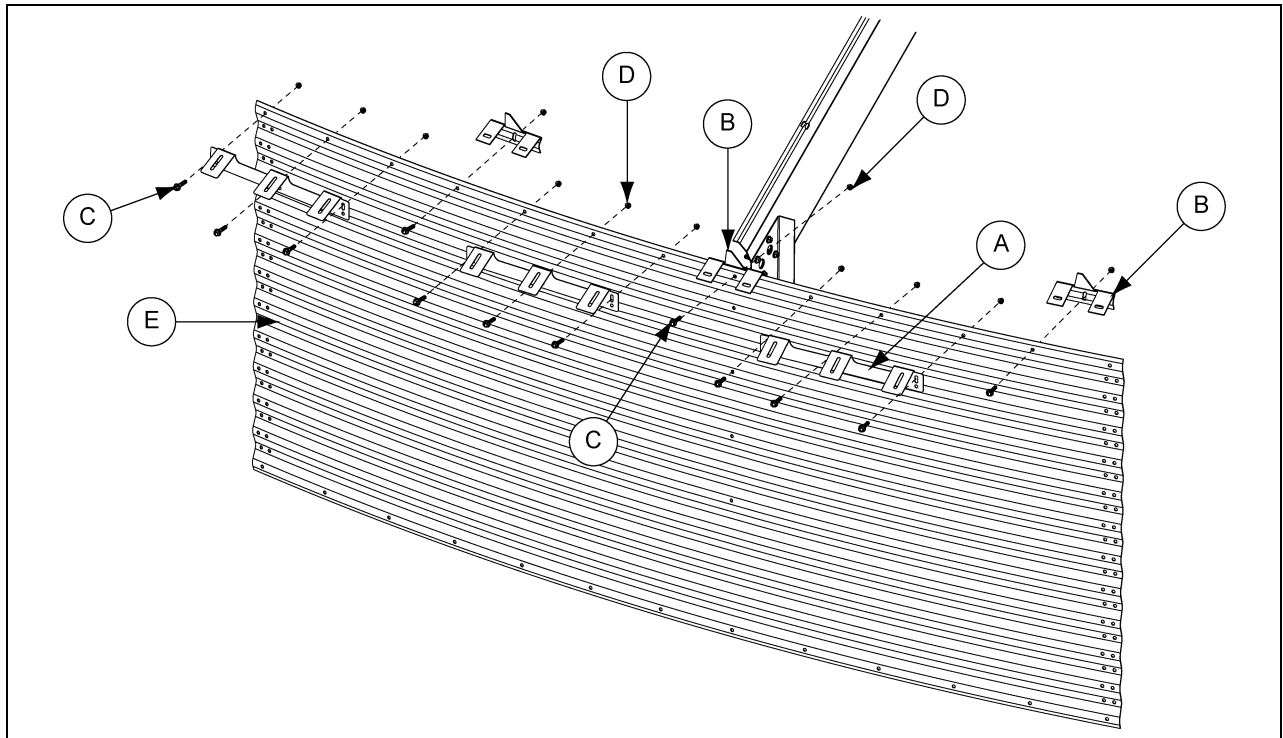

Figure 8B Installing the Eave Clip and Intermediate Eave Angle to the Sidewall Sheet

Ref #	Part #	Description
A	CTR-1183	Intermediate Eave Angle
B	R-007-1	Eave Clip
C	S-10260	5/16" x 1" Flange Bolt with Sealing Washer
D	S-3611	5/16" Flange Nut
E		Sidewall Sheet

Attaching the Roof Stiffener Clips to the Rafter

Roof stiffener clips secure the rafter to the center collar.

What You Should Know

Each roof rafter receives two (2) roof stiffener clips.

1. Determine the correct orientation of each rafter (A) by identifying the roof panel holes (E) located near the end of each rafter (A).
2. Install roof stiffener clips (B) to both sides of the roof rafter (A).
3. Use flange bolts (C) and flange nuts (D) to secure the roof stiffener clips (B) to the rafter (A). Tighten to the recommended torque specification. See bolt torque specifications on [Page 30](#).

NOTE: Make sure to install and tighten the bolts and nuts only on the holes shown in [Figure 8C](#).

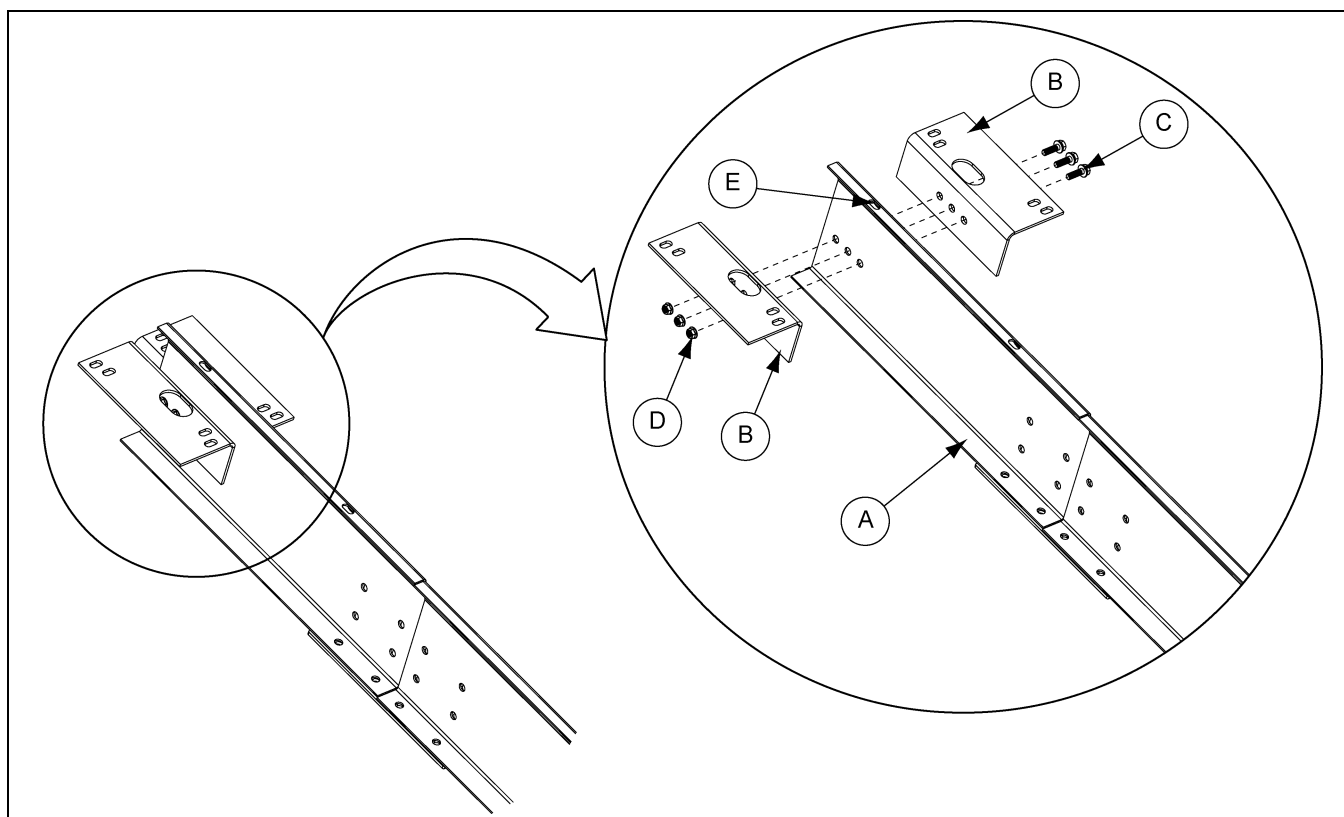

Figure 8C Exploded View of Roof Stiffener Clips

Ref #	Part #	Description
A	CTR-1546	Upper Roof Rafter
B	CRP-5268	Roof Stiffener Clips
C	S-7488	3/8" x 1-1/2" Flange Bolt
D	S-9426	3/8" Flange Nut
E		Roof Panel Hole

After You Finish

Repeat this process for the remaining roof rafters.

8. Roof Assembly

Center Collar Placement

The following figure gives the approximate height needed to install the center collar.

With one sidewall ring in place, position the center collar at the height specified, measuring from the bottom of the center collar to the foundation as shown. If additional rings are required for construction purposes, add 44" for each additional ring.

NOTE: *It is better to set the center collar a little too high. Do not set the center collar too low.*

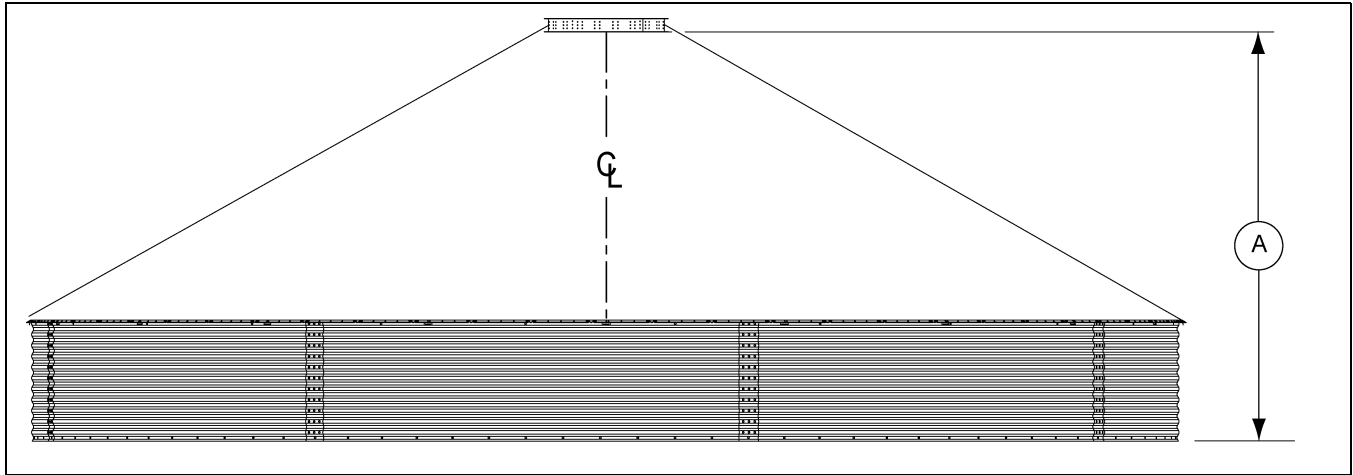

Figure 8D Center Collar Placement

Ref #	Description
A	196" (16'-4") (497.84 cm) from foundation to bottom of center collar on 48' diameter bin.

NOTE: *Make sure the center pole is adjustable up and down.*

Assembling the Center Collar

The standard roof with a dome cap lid will have a center collar assembled from three (3) pieces. The dome cap will mount onto it as well as the flashing. The dome cap is standard on all 48' 40-Series bins.

Assemble the three (3) center collar (A) pieces together using flange bolts (B) and flange nuts (C).

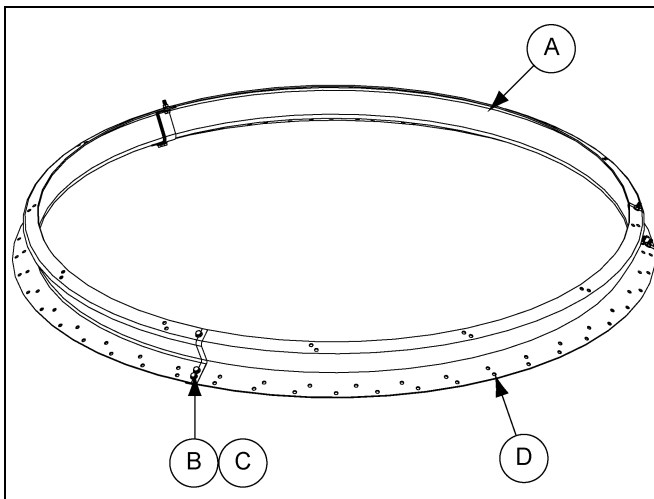

Figure 8E Assembling the Center Collar

Ref #	Part #	Description
A	CTR-0796	Center Collar
B	S-10260	5/16" x 1" Flange Bolt with Sealing Washer
C	S-3611	5/16" Flange Nut
D		NOTE: <i>The lower set of holes (D) in the center collar are not used.</i>

Assembling the Roof Flashing Angle

1. Position the roof flashing angles (B) as shown in [Figure 8F](#). Field drill the center collar pieces (A) through the roof flashing angles (B) and install the flange bolts (C) and flange nuts (D). Tighten to the recommended torque specification. See bolt torque specifications on [Page 30](#).

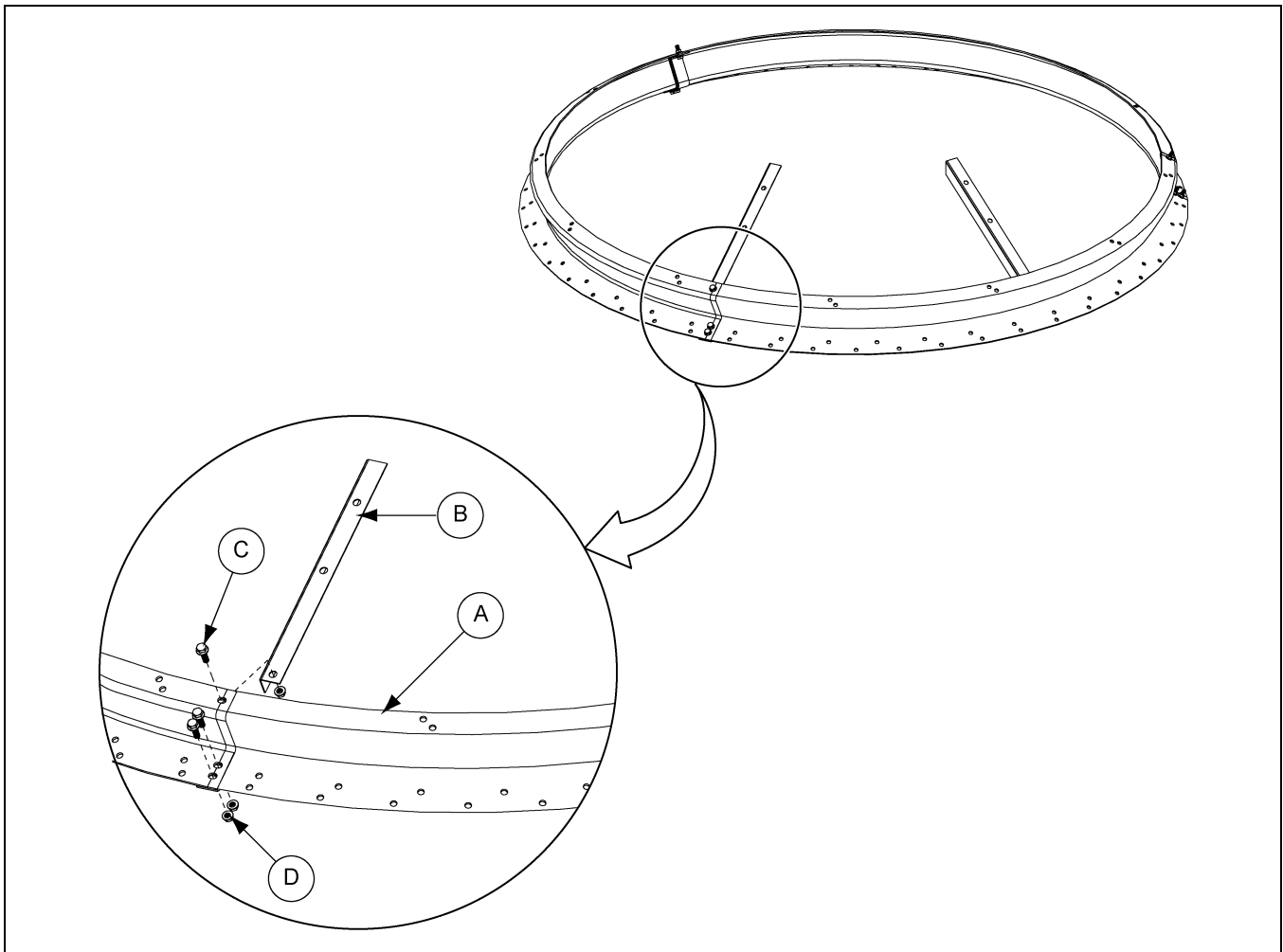

Figure 8F *Assembling the Roof Flashing Angle*

Ref #	Part #	Description
A	CTR-0796	Center Collar
B	CRP-6188	Roof Flashing Angle
C	S-10260	5/16" x 1" Flange Bolt with Sealing Washer
D	S-3611	5/16" Flange Nut

8. Roof Assembly

Assembling the Rafters

What You Should Know

Each rafter will consist of a three (3) piece design and will need to be spliced together for assembling the rafter onto the roof.

1. Locate an upper rafter (A) and a middle rafter (B) and find the series of holes on each end of the two (2) rafters.

NOTE: Assemble rafters with the flanges facing in the same direction.

2. Place the middle rafter (B) in line with the upper rafter (A) and attach a rafter splice (D) to outside mating surface of the two (2) rafters.

NOTE: Make sure that the flange of rafter splice (D) is facing down and seated below the flange of the rafters. Secure the flange of rafter splice (D) to the flange of the rafters using four flange bolts (H) and four flange nuts (I).

3. Install the eight flange bolts (H) and eight flange nuts (I) securing the rafters (A and B) to the rafter splice (D).
4. Place the middle rafter (B) in line with the lower rafter (C) and attach a rafter splice (D) to outside mating surface of the two (2) rafters.
5. Install the six flange bolts (H) and six flange nuts (I) securing the rafters (B and C) to the rafter splice (D).
6. Position the purlin clips (E) on both sides of the rafter as shown and install the two (2) flange bolts (F) and two (2) flange nuts (G) securing the rafters and purlin clips to the rafter splice.

NOTE: Make sure that the purlin clips are positioned on the two (2) holes in the second column of holes on each side of the rafter.

7. Tighten all the hardware to the recommended torque specifications. See bolt torque specifications on [Page 30](#).

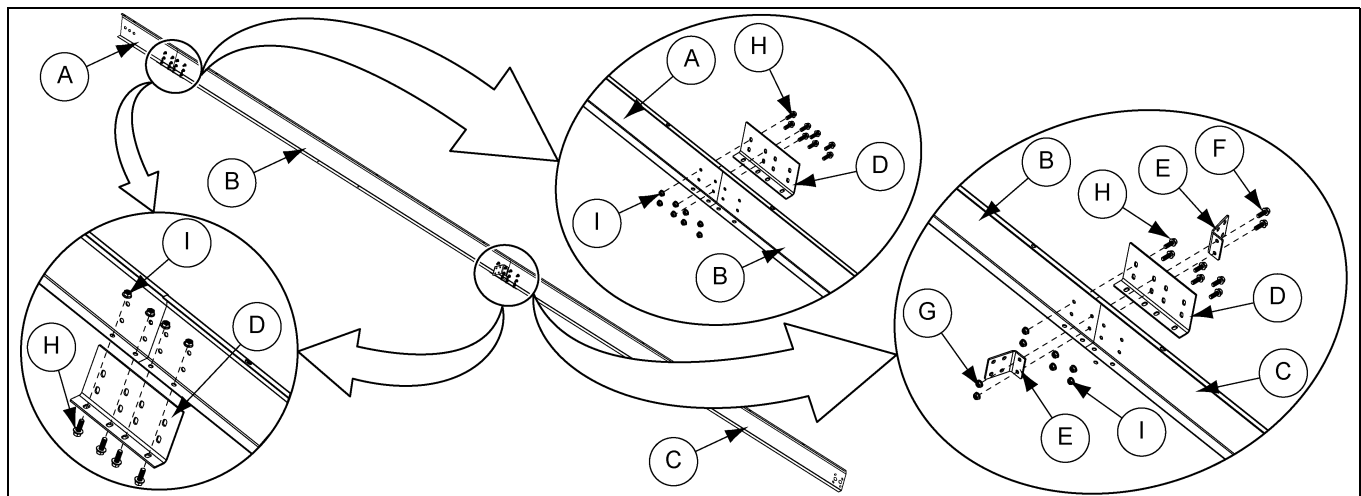

Figure 8G Assembling the Rafters

Ref #	Part #	Description
A	CTR-1546	Upper Rafter
B	CTR-1348	Middle Rafter
C	CTR-1341	Lower Rafter
D	PR-1874	Roof Stiffener Splice
E	CTR-1434	Purlin Clip

Ref #	Part #	Description
F	S-7486	3/8" x 1-1/2" Flange Bolt
G	S-9426	3/8" Flange Nut
H	S-7485	3/8" x 1" Flange Bolt
I	S-9426	3/8" Flange Nut

After You Finish

Repeat this procedure for the remaining rafters.

Attaching the Rafter Assembly to Roof Rafter Bracket

Install the lower portion of the rafter assembly to the roof rafter bracket.

1. Position and align the lower portion of the rafter assembly (outside surface) (D) to the roof rafter bracket (A).
2. Install flange bolts (B) and flange nuts (C), securing the rafter assembly (D) to the roof rafter bracket (A).
3. Tighten the hardware to the recommended torque specifications. See bolt torque specifications on [Page 30](#).

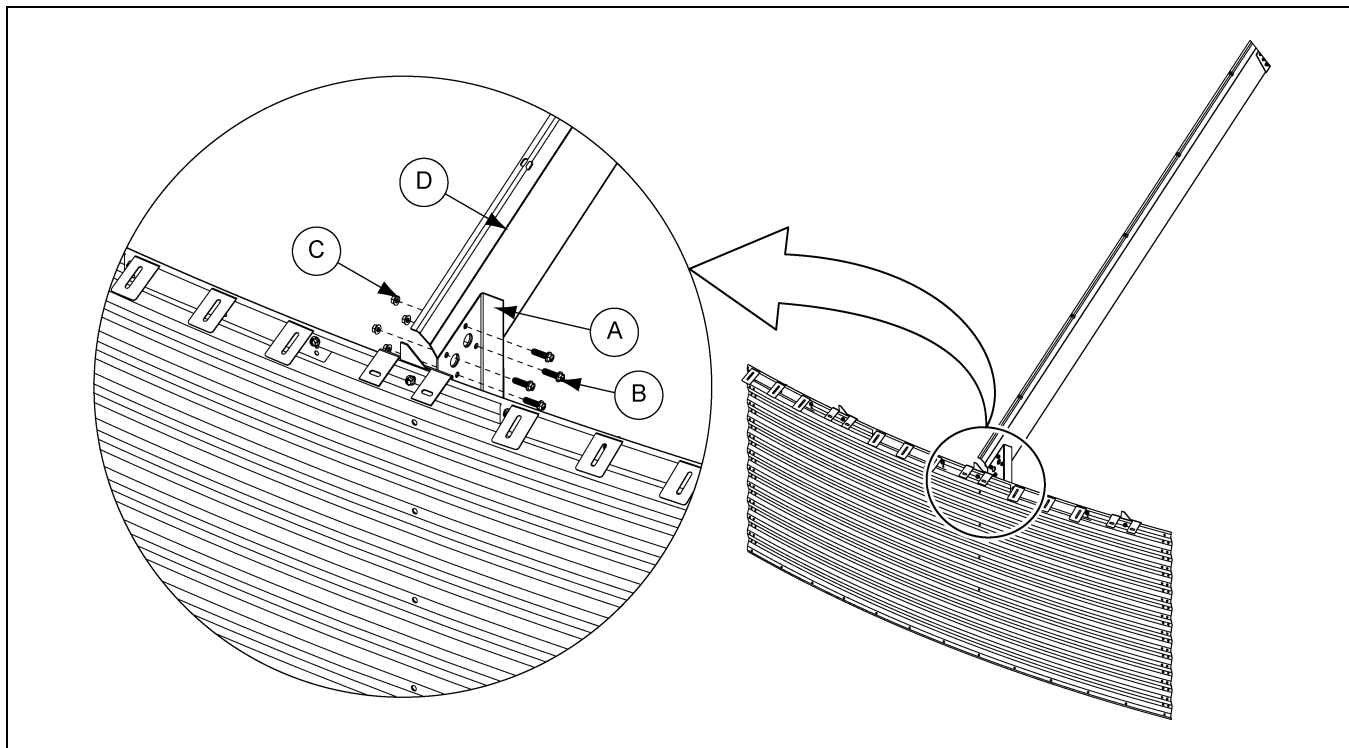

Figure 8H Attaching the Rafter Assembly to the Roof Rafter Stiffener

Ref #	Part #	Description
A	CTR-1364	Roof Rafter Bracket
B	S-7485	3/8" x 1" Flange Bolt
C	S-9426	3/8" Flange Nut
D	CTR-1341	Lower Rafter Assembly

After You Finish

Repeat this procedure to assemble the remaining rafter assemblies to the rafter bracket.

8. Roof Assembly

Attaching the Rafter Assembly to Center Collar

The rafter assembly must be installed to support the center collar weldment and main roof structure.

Before You Begin

The center collar should be assembled and secured to the support pole and the rafter assembly should be assembled. Determine the correct location of each rafter assembly. For more information, see center collar placement on [Page 50](#).

What You Should Know

Make sure the other end of the rafter assembly (D) is connected to the roof truss stiffener.

1. Attach the rafter assembly (D) to the center collar (A) and align with the proper holes as shown in [Figure 8I](#).
2. Install the flange bolts (B) and flange nuts (C) to secure the rafter assembly (D) to the center collar (A).
3. Tighten the hardware to the recommended torque specifications. See bolt torque specifications on [Page 30](#).

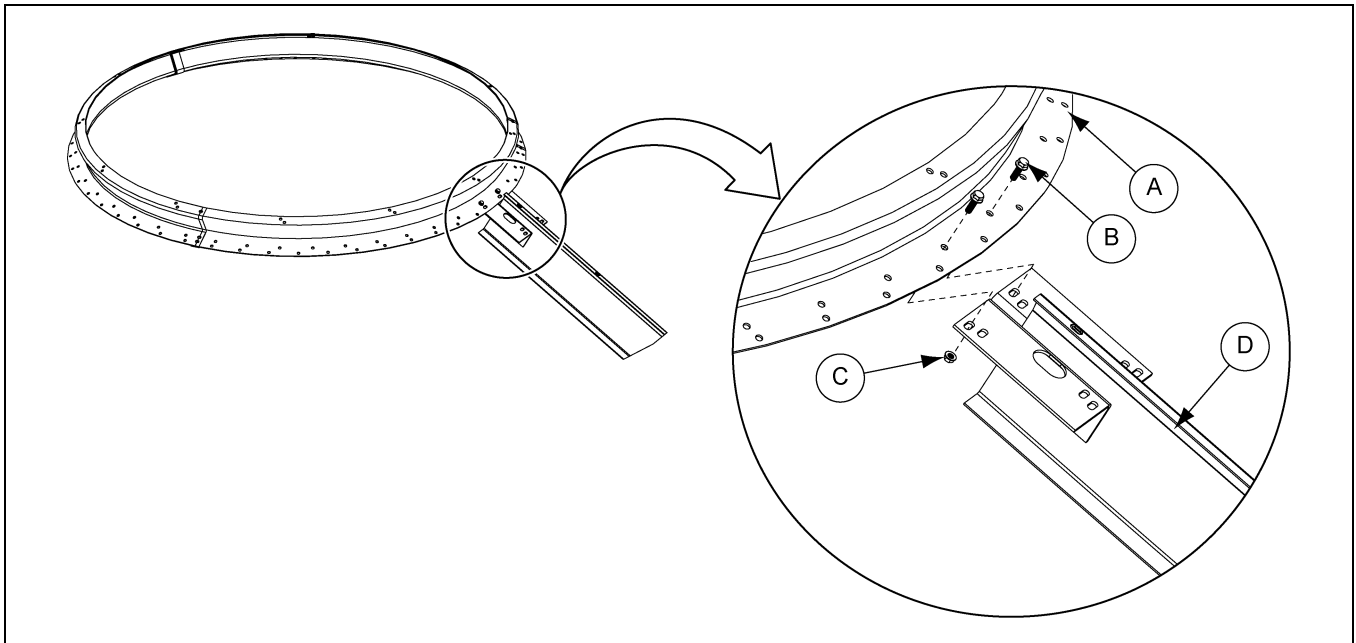

Figure 8I Install the Rafter Assembly to the Center Collar Weldment

Ref #	Part #	Description
A	CTR-0796	Center Collar
B	S-10260	5/16" x 1" Flange Bolt with Sealing Washer
C	S-3611	5/16" Flange Nut
D	CTR-1546	Upper Roof Rafter Assembly

After You Finish

Repeat same procedure for the rest of the rafter assemblies

Assembling the Purlin

Purlins are horizontal members between the rafters that give support to the roof structure. The length of the purlin determines its location on the rafter assembly.

Before You Begin

All roof rafter assemblies must be installed and secured to both the center collar and roof rafter brackets.

What You Should Know

Purlins are installed between two (2) rafters.

1. Install the purlin (A) to the left purlin clip (C) and right purlin clip (B) with the flange bolts (D) and flange nuts (E).

NOTE: Make sure that the purlins (A) are installed with the rib support clip holes facing up and also the flanges are facing the purlin clips.

2. Install the rib support clips (F) on purlins (A) with flange bolts (G) and flange nuts (H) as shown.
3. Tighten the hardware to the recommended torque specifications. See bolt torque specifications on [Page 30](#).

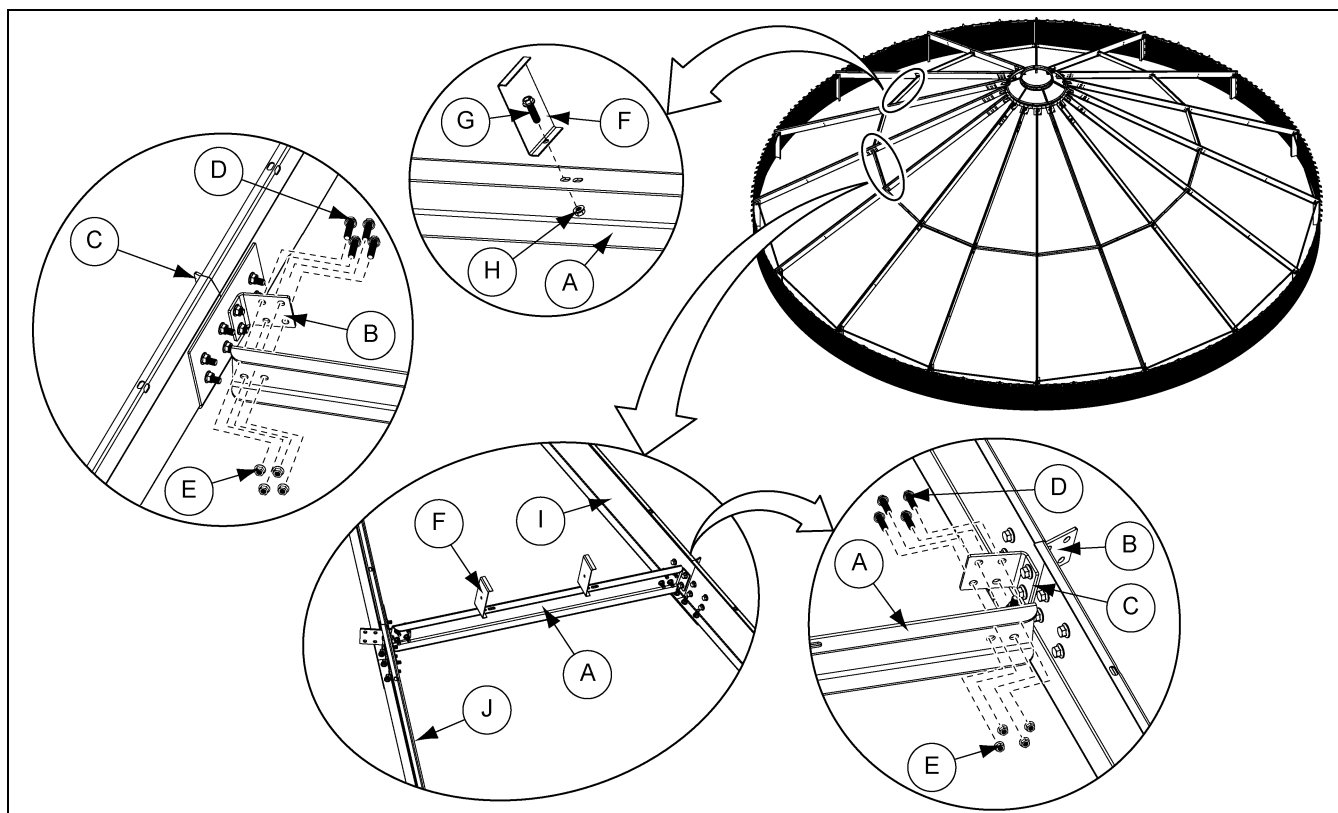

Figure 8J Assembling the Purlins

Ref #	Part #	Description	Ref #	Part #	Description
A	CTR-1400	Purlin	F	CTR-1405	Rib Support Clip
B	CTR-1434	Right Purlin Clip	G	S-10260	5/16" x 1" Flange Bolt with Sealing Washer
C	CTR-1434	Left Purlin Clip	H	S-3611	5/16" Flange Nut
D	S-7485	3/8" x 1" Flange Bolt	I		Right Rafter Assembly
E	S-9426	3/8" Flange Nut	J		Left Rafter Assembly

8. Roof Assembly

Installing the Tension Rods

Tension rods connect to the rafter brackets through the rafter and are installed around the inside of the bin.

Before You Begin

Make sure all the rafters are installed before proceeding the installation of tension rods.

What You Should Know

1. Install the tension rods (A) between the two (2) rafter brackets (B) with washers (C) and nuts (D) as shown in [Figure 8K](#).

NOTE: Make sure that both ends of the tension rod (A) installed to the first hole from eave side of the rafters.

2. Install the next tension rod (A) between the two (2) rafter bracket (B) on the second hole from the eave with washers (C) and nuts (D) as shown.

NOTE: Adjust tension rods (A) to slight tension (do not overtighten), before removing center support jack.

3. Tighten the hardware to the recommended torque specifications. See bolt torque specifications on [Page 30](#).

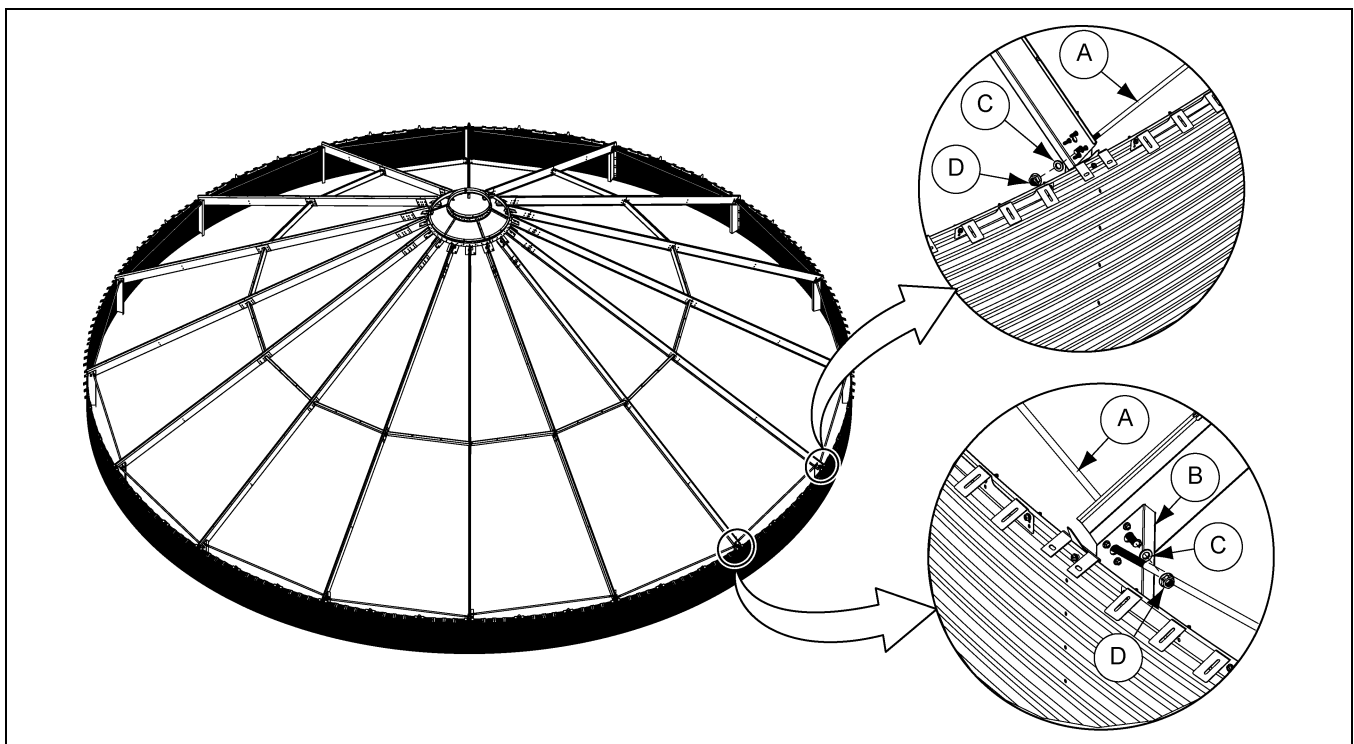

Figure 8K Installation of the Tension Rods

Ref #	Part #	Description
A	CRP-7129	1" Tension Rod
B	CTR-1364	Roof Rafter Bracket
C	S-866	3/4" Washer
D	S-234	3/4" Nut

Installing the Temperature Cable Support Brackets (Optional)

Before You Begin

This information is provided solely for the purpose of facilitating proper support bracket placement. It is fully the responsibility of the dealer, customer, contractor, or said agent of such parties to confirm the details of the system to be used. GSI is not responsible for the effectiveness or performance of any temperature cable monitoring system or layout.

NOTE: *Temperature cables must terminate above any unload equipment and be secured in place with twine. DO NOT allow cables to become tangled in unload equipment.*

What You Should Know

The temperature cable support channels and temperature cable brackets can be installed after the rafters and purlins are installed onto the roof.

1. Attach a temperature cable support angle (B) to each rafters (F) using flange bolts (D) and flange nuts (E).

NOTE: *Field drill the holes in the rafters (F) for installing the temperature cable support angles (B).*

2. Attach the temperature cable support channel (A) to the temperature cable support angles (B) with flange bolts (D) and flange nuts (E).
3. Install the temperature cable hanging bracket (C) to the center of the temperature cable support channel (A) with the flange bolts (D) and flange nuts (E) as shown.

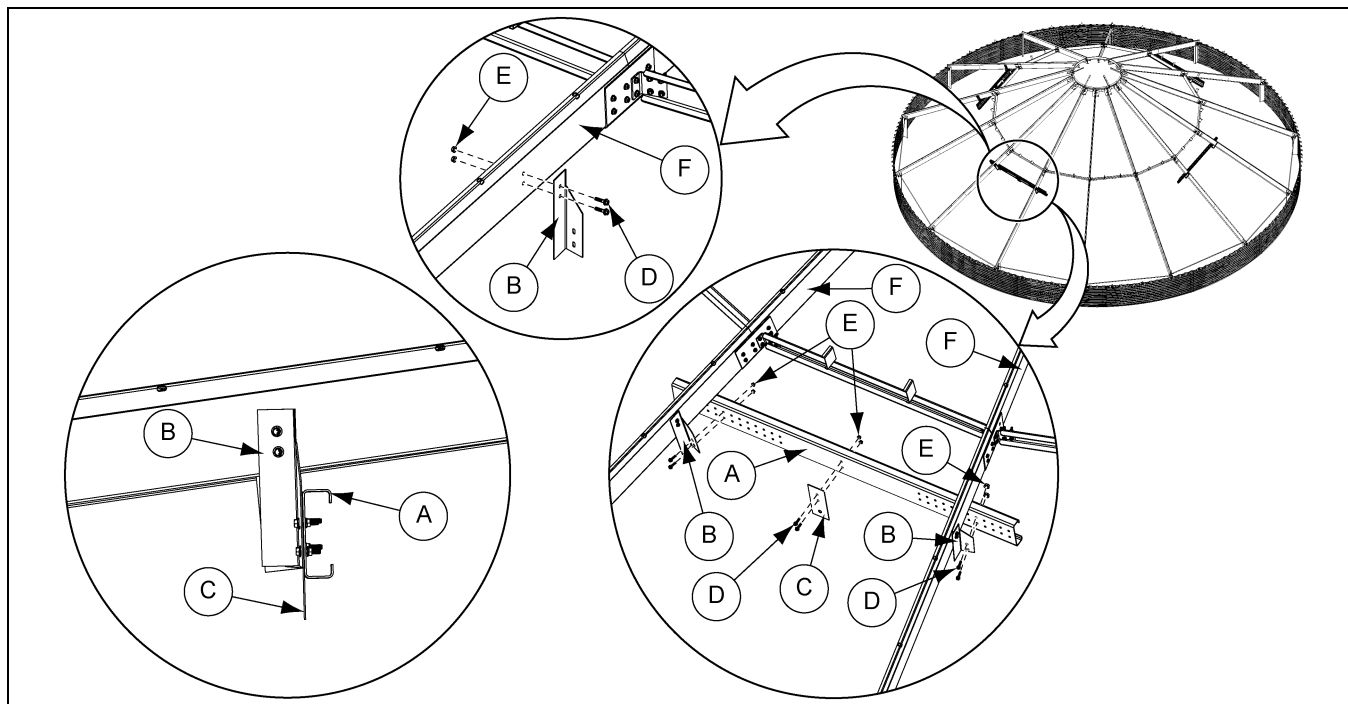

Figure 8L *Installing a Temperature Cable Support Channel*

Ref #	Part #	Description
A	CRP-5285	Temperature Cable Support Channel
B	CRP-5786 and CRP-5787	Temperature Cable Support Angle
C	CRP-5213	Temperature Cable Hanging Bracket

Ref #	Part #	Description
D	S-7488	3/8" x 1-1/2" Flange Bolt
E	S-9426	3/8" Flange Nut
F		Roof Rafter

8. Roof Assembly

4. Install a quick link (C) to each cable bracket to support the temperature cables.

IMPORTANT: Do not attach weights to the temperature cables; secure the bottom of cables to the floor with light twine. No roof rafter shall support more than one cable.

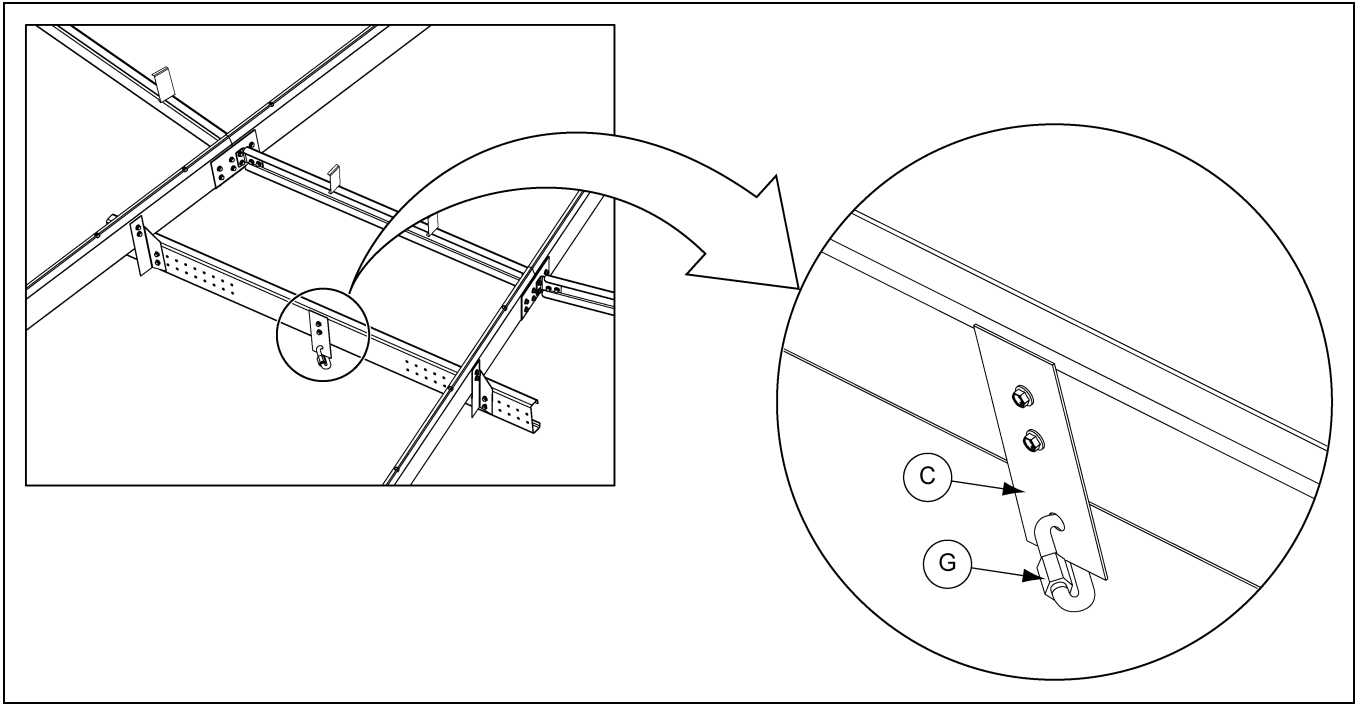

Figure 8M Supplier Quick Link

Ref #	Description
C	Temperature Cable Hanging Bracket (CRP-5213)
G	Supplier Quick Link

Installing the Roof Panels

Roof panels overlap the previous roof panel, giving protection from outside elements. Rafters and rib support clips will support to hold the roof panels.

Before You Begin

Ensure all roof rafter assemblies and purlins are installed and properly tightened. Pre-determine the manway access location.

What You Should Know

For better results and adjustment purposes, four (4) groups of two (2) roof panels (A) each are installed first, causing exposed gaps (B) between each roof panel group. (See [Figure 8N.](#)) After all roof panels (A) are installed, ensure that all installed hardware (flange bolts with sealing washers and flange nuts) are tightened to secure the roof panels.

When installing the roof panels, take into consideration placing the manway for ease of access to and from the sidewall and roof ladders.

1. Place two (2) roof panels overlapping, with the roof panel ribs resting on the rafter. Repeat the same procedure at four (4) locations as shown in [Figure 8N.](#)

IMPORTANT: Install the roof panels in counterclockwise direction and ensure that the small rib (lower rib) (D) is tucked under the large rib (upper rib) (C).

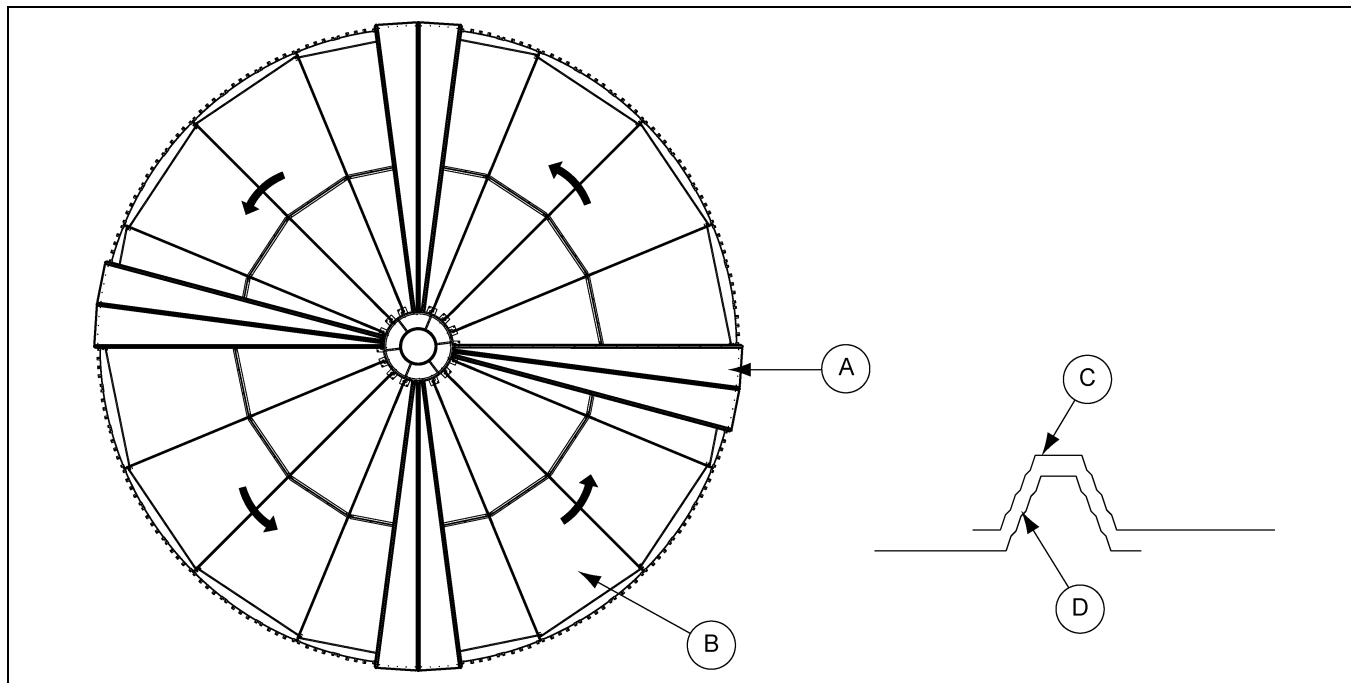

Figure 8N Roof Panel Overview

Ref #	Description
A	Roof Panel (CTR-0390)
B	Exposed Gap
C	Upper Rib
D	Lower Rib

8. Roof Assembly

2. Secure the roof panel ribs to the rafter (J) with the flange bolts (G) and flange nuts (H).
3. Install the flange bolts (G) and flange nuts (H) securing the bottom portion of the roof panel (A) to the eave clip (K) and intermediate eave angle (F).

NOTE: Do not tighten bolts until the roof is completely assembled.

NOTE: Skip installing the bolts and nuts at the location shown (I), to ease the installation of the adjacent roof panel.

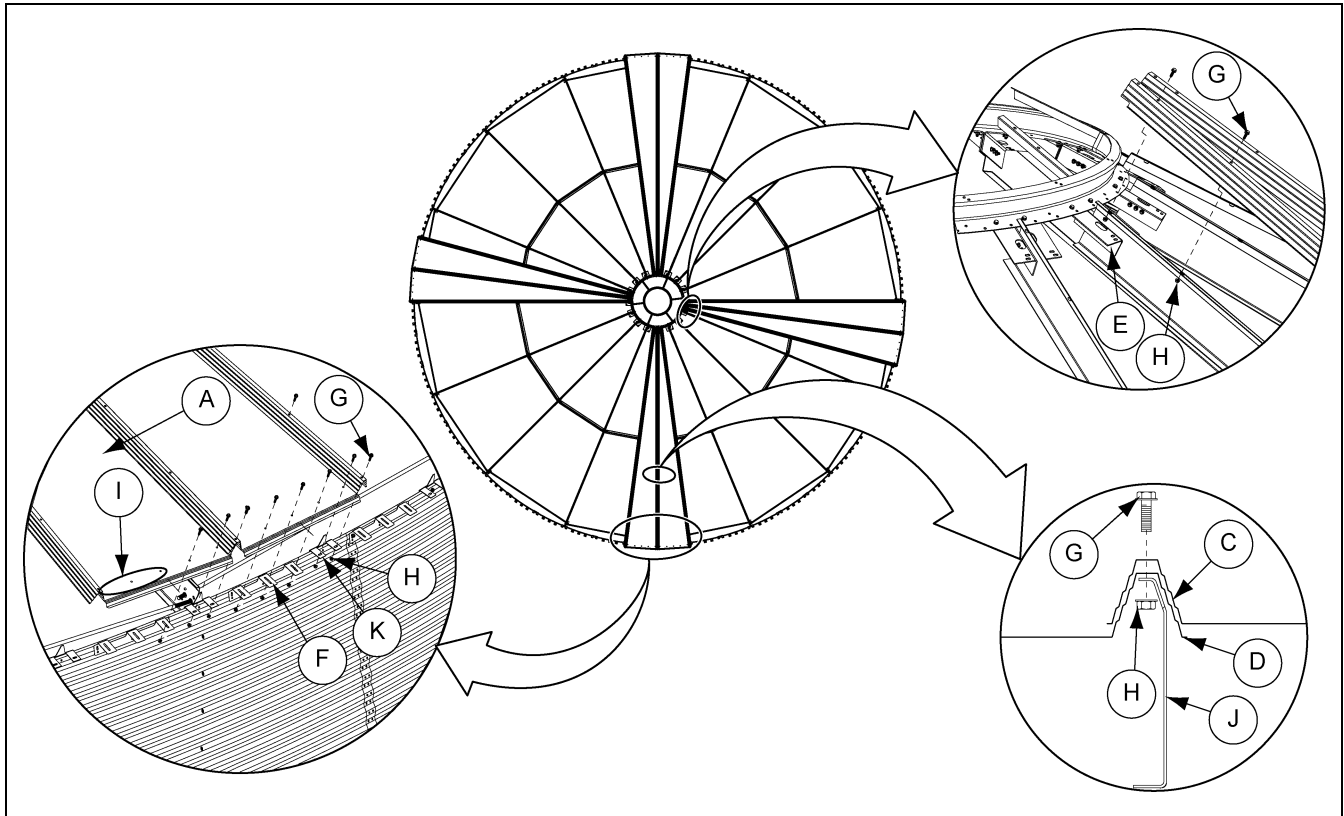

Figure 80 Installing Roof Panels

Ref #	Part #	Description
A	CTR-0390	Roof Panel
C		Upper Rib
D		Lower Rib
E	CRP-5268	Roof Stiffener Clip
F	CTR-1183	Intermediate Eave Angle
G	S-10260	5/16" x 1" Flange Bolt with Sealing Washer
H	S-3611	5/16" Flange Nut
I		Skip Bolt Holes
J	CTR-1341	Roof Rafter
K	R-007-1	Eave Clip

4. Make sure that the roof panel ribs are supported on the rib support clips (M).
5. After the initial roof panels (A) are installed, fill in the exposed gaps (B). Working in a counterclockwise direction, install two (2) additional roof panels (as shown), overlapping each roof panel on the left.

IMPORTANT: Tuck the last roof panel per gap under the previously installed roof panel by slightly lifting the side rib and allowing the new adjacent roof panel to be tucked under the previously installed roof panel (A).

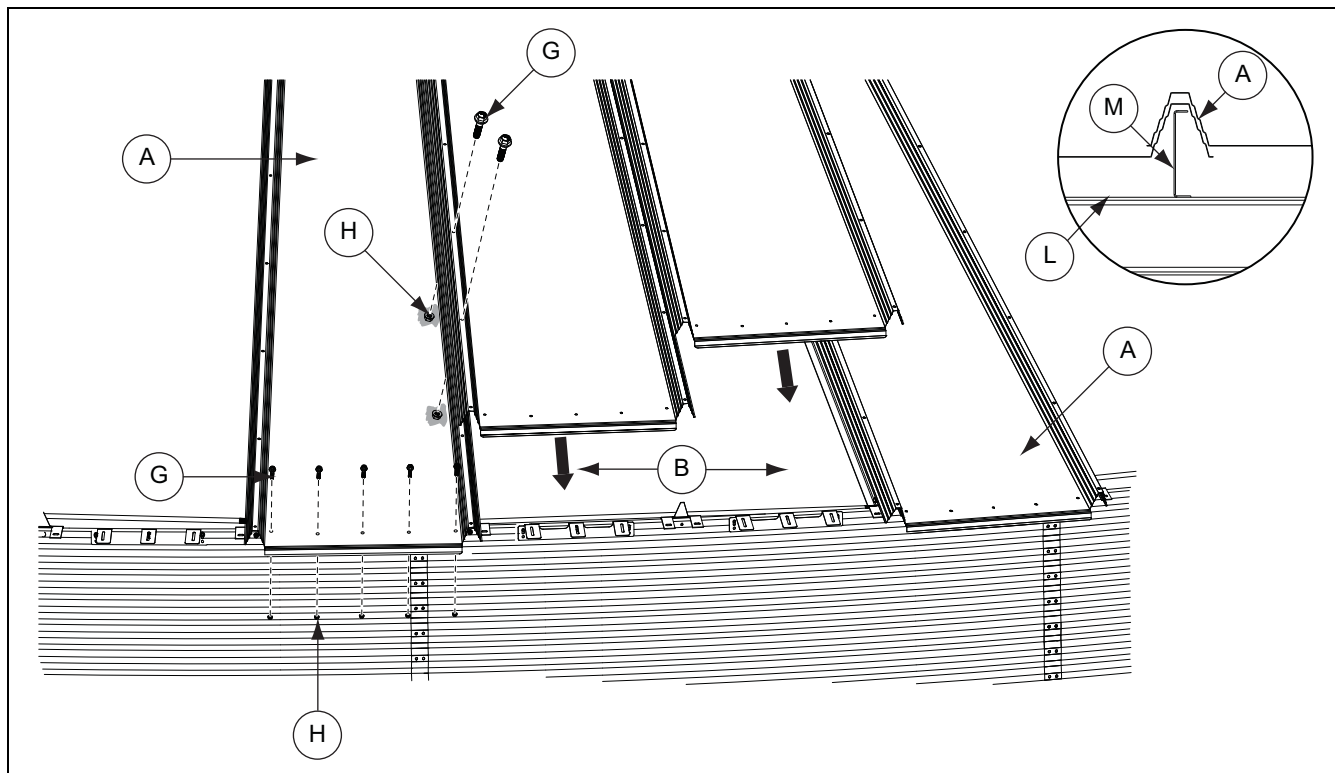

Figure 8P Installing Roof Panels into Exposed Gaps

Ref #	Part #	Description
A	CTR-0390	Roof Panel
B		Exposed Gap
G	S-10260	5/16" x 1" Flange Bolt with Sealing Washer
H	S-3611	5/16" Flange Nut
L	CTR-1400	Purlin
M		Rib Support Clip

5. When all roof panels within a group are in place, install the remaining flange bolts and flange nuts along the roof ribs and tighten.

IMPORTANT: Failure to properly secure the roof panel to the roof panel support clips and the rafter will constitute a modification to the product not specifically delineated in this manual and will void the limited warranty.

5. Tighten all hardware to the recommended torque specifications. See bolt torque specifications on [Page 30](#).

8. Roof Assembly

Installing the Roof Flashing

The roof flashing will seal the area between the center collar and the roof panels.

What You Should Know

Each roof flashing section (A) overlaps and bolts together with the previously installed roof flashing section (A).

1. Install the first roof flashing section (A) onto the center collar (B) and align the holes in the roof flashing section (A) with roof flashing angle holes (C) as shown in [Figure 8Q](#).
2. Install flange bolts (E) and flange nuts (F), securing the first roof flashing section (A) to the roof flashing angle (C).
3. Field drill holes on the center collar (B) through the roof flashing section (A). Fasten the roof flashing section (A) and centre collar (B) securely using flange bolts (E) and flange nuts (F).

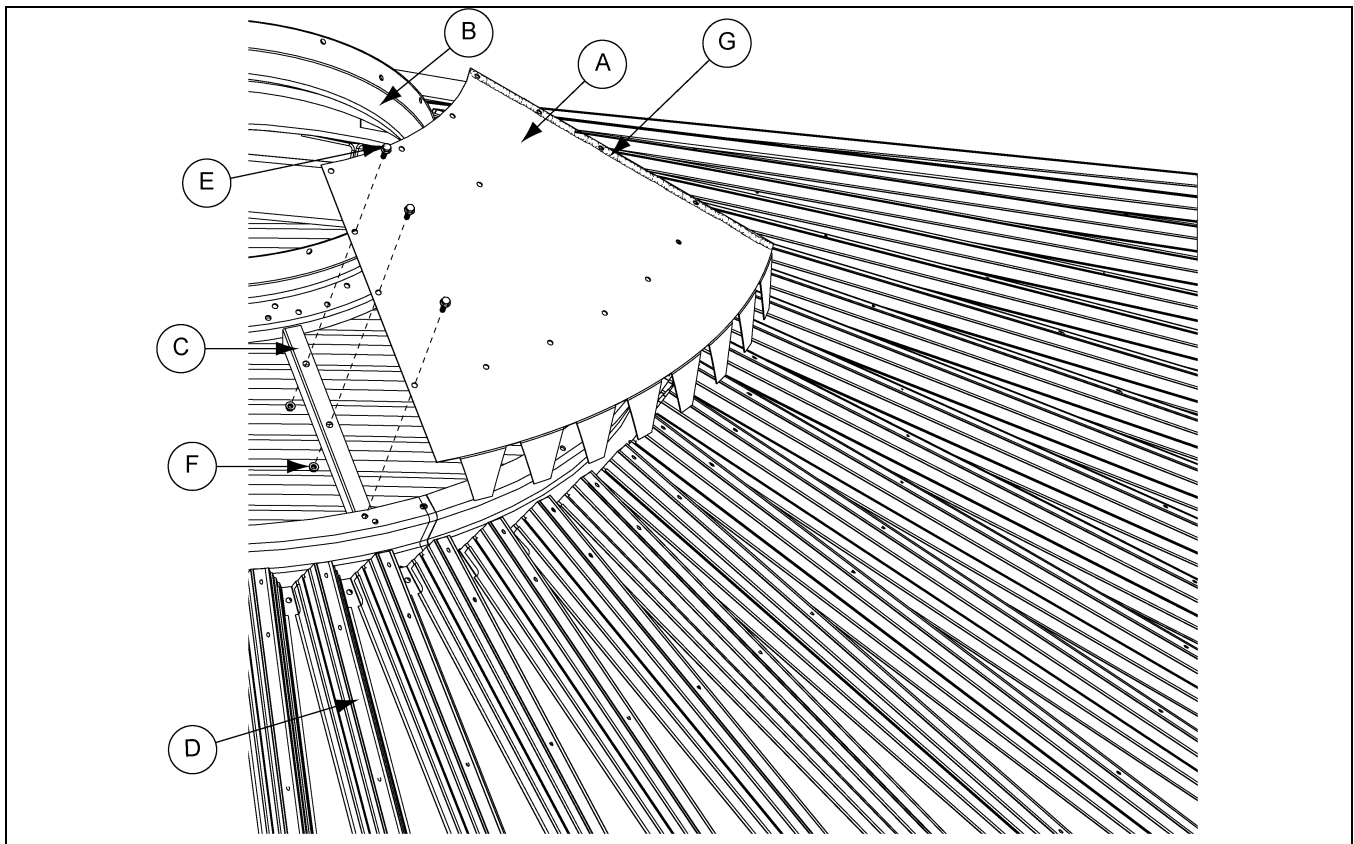

Figure 8Q Installation of First Roof Flashing Section

Ref #	Part #	Description
A	CRP-4686	Roof Flashing Section
B	CTR-0796	Center Collar
C	CRP-6188	Roof Flashing Angle
D	CTR-0390	Roof Panel

Ref #	Part #	Description
E	S-10260	5/16" x 1" Flange Bolt with Sealing Washer
F	S-3611	5/16" Flange Nut
G	S-4458	Rope Caulk

4. Place a strip of rope caulk (G) along the edge of the installed roof flashing (A) where the next roof flashing will overlap.

5. Align the holes along the edge of the next roof flashing (A) with the holes of the previously installed roof flashing holes and with the roof flashing angle (C).
6. Install flange bolts (E) and flange nuts (F), securing the other two (2) roof flashing sections (A) together.
7. Install flange bolts (E) and flange nuts (F), securing the first roof flashing section (A) to the roof flashing angle (C).
8. Continue installing the remaining flashing until the gap between the center collar (B) and roof panels (D) is covered.

NOTE: Remember to place caulk between the overlap of the last two (2) panels.

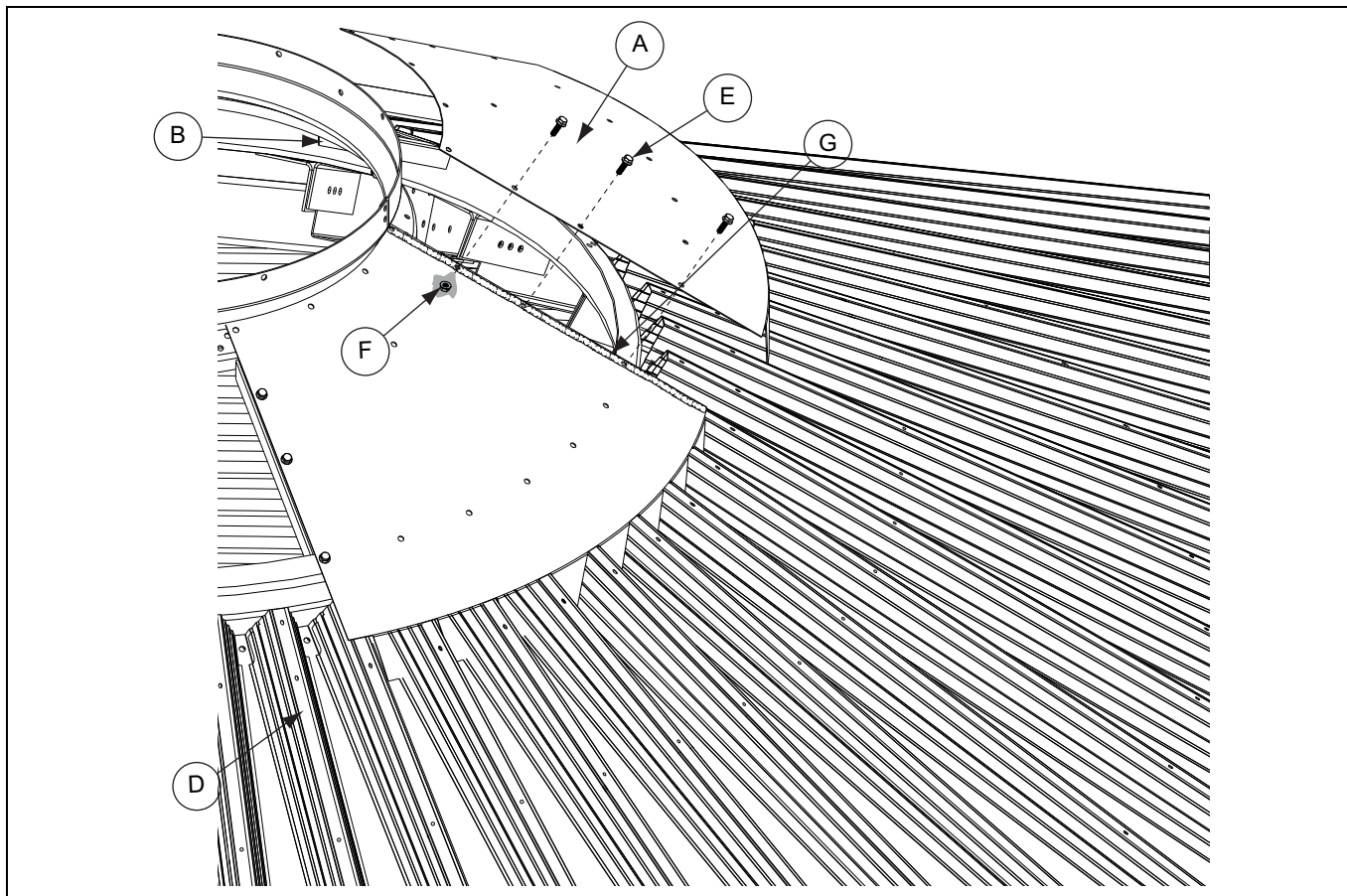

Figure 8R Installation of Remaining Roof Flashing Sections

Ref #	Part #	Description
A	CRP-4686	Roof Flashing Section
B	CTR-0796	Center Collar
D	CTR-0390	Roof Panel
E	S-10260	5/16" x 1" Flange Bolt with Sealing Washer
F	S-3611	5/16" Flange Nut
G	S-4458	Rope Caulk

8. Roof Assembly

Roof Ring Placement (Optional)

The roof ring is a tubular ring bolted to the exterior of the roof.

The placement location and quantity of roof ring kits vary with the size of each bin. The roof support ring (A) on the 48' bin will be installed in the seventh (7th) roof panel rib hole from the eave. The eave roof ring (B) will be installed in the last roof panel rib hole located at the eave end of the bin.

NOTE: *If ladder steps have been installed, and not already omitted, remove the ladder step that is installed in the same roof panel rib hole in which the roof ring will be installed.*

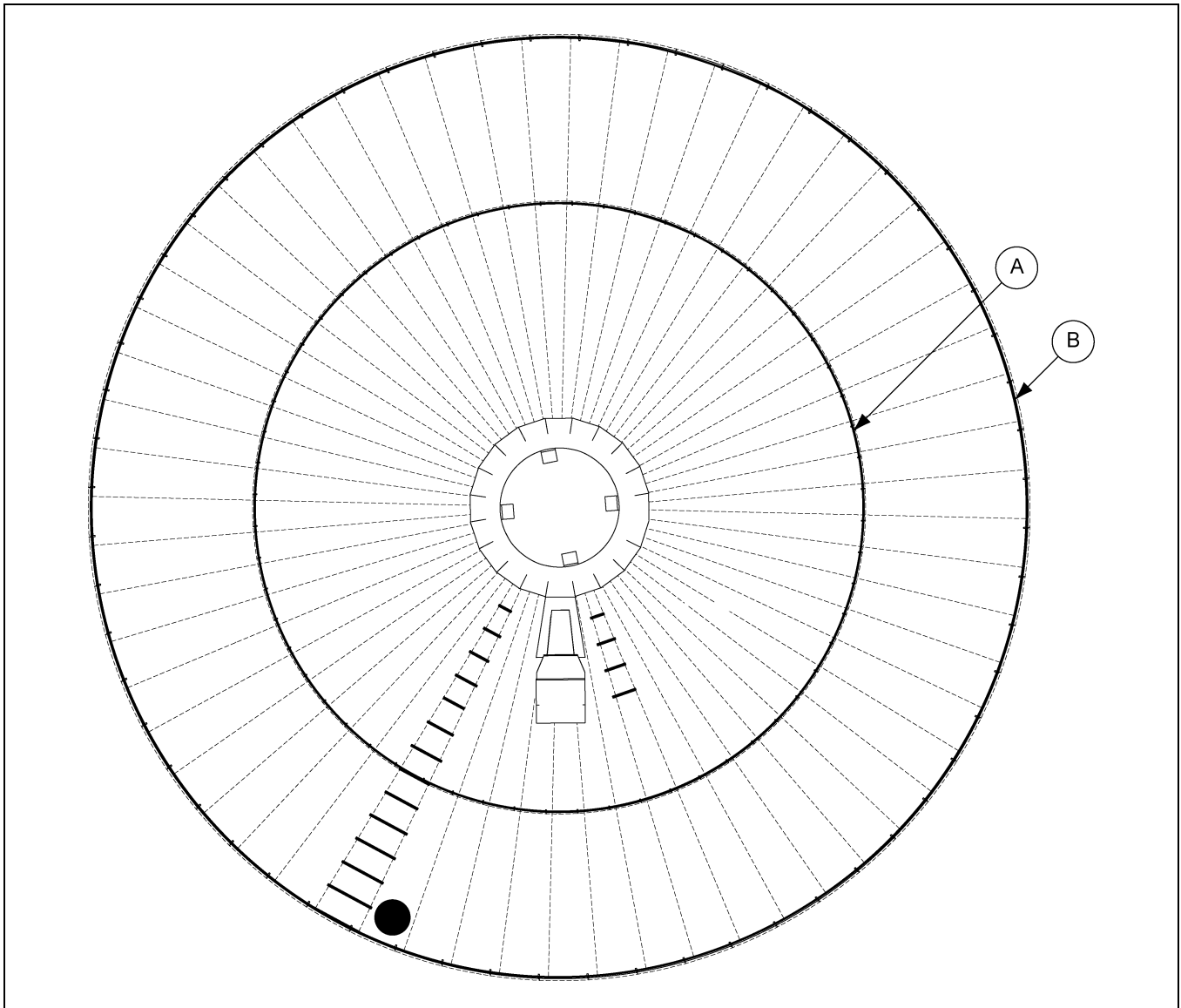

Figure 8S Roof Ring Location on Bin

Ref #	Part #	Description
A	CRP-4755	Roof Support Ring
B	CRP-5496-48	Eave Roof Ring Kit

Installing a Roof Ring

Quantity and part numbers of roof ring kits vary with the location placement and with the size of each bin. The following procedure will be similar for each kit.

1. Determine the quantity of roof ring clips (C) needed for the roof ring section (B) being installed.

NOTE: Each roof panel rib must have a roof ring clip installed.

2. Install a flange bolt (A) to the roof ring clip (C) and install a sealing washer (E) to the underside of the roof ring clip (C).
3. Slide each assembled roof ring clip (C) onto a roof ring section (B) and position each roof ring clip (C) over each roof panel rib.
4. Install a flange nut (D) to each roof ring clip (C).

NOTE: Do not tighten hardware until all roof ring sections have been installed.

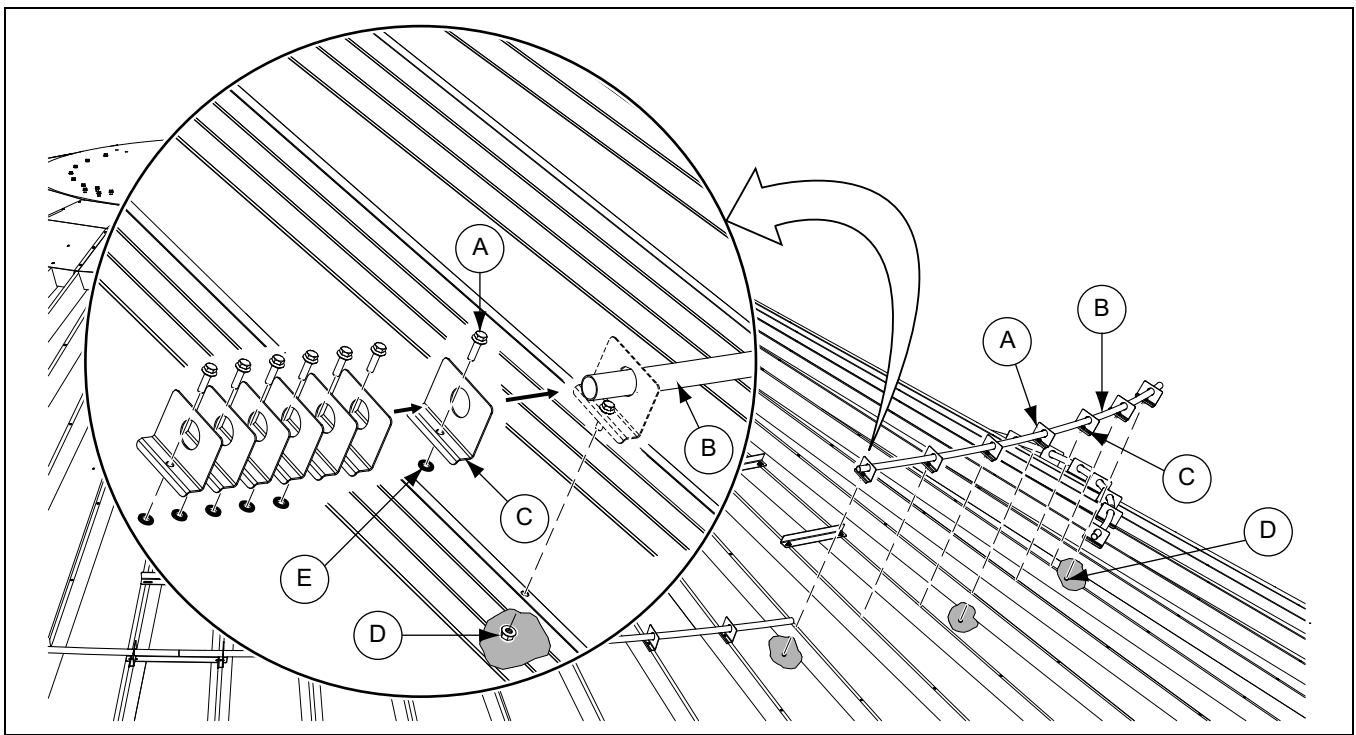

Figure 8T Roof Ring Shown

Ref #	Part #	Description
A	S-10260	5/16" x 1" Flange Bolt with Sealing Washer
B		Roof Ring Section
C	R-997	Roof Ring Clip

Ref #	Part #	Description
D	S-3611	5/16" Flange Nut
E	S-10303	Sealing Washer

Diameter	Roof Ring (B)	
	Exhauster/Support Roof Ring Section	Eave Roof Ring Section
48'	CRP-4753	CRP-5497-48

8. Roof Assembly

Installing a Roof Ring (Continued)

5. Locate a threaded stud (F) and install stud nuts (G) evenly and to the center of the threaded stud (F).
6. Install the threaded stud (F) with stud nuts (G) to the end of the roof ring section (B).

NOTE: *Install the threaded stud (F) to the side where the next roof ring section will be installed.*

7. Repeat this process, installing each new roof ring section end onto the preceding threaded stud just installed.
8. When all roof ring sections are installed, tighten each roof ring clip (B).
9. Adjust each stud nut (G) outward, expanding each roof ring section. Continue this procedure evenly until the roof ring raises the roof, showing a slight crown.

NOTE: *Expansion bolts should be fully contracted when assembling support rings. When you have completely assembled both rings, (but prior to expanding the bolts) tighten all roof bolts including eave clip bolts. Now extend expansion bolts by running the nut out on the threads. This procedure should be continued evenly around the roof until the ring raises the roof to show a slight crown.*

NOTE: *Roof ring expansion bolts may become dislodged from the roof ring during the life of the bin due to the influence of wind or other factors. If one expansion bolt is dislodged, the entire ring will become ineffective. After expansion to the jam nuts final position, the nuts on the expansion bolt should be secured to prevent this. This may be done by staking the expansion bolt threads at the jam nut location, use of suitable thread locking compounds or other effective methods. (See Figure 8U.)*

In addition, drilling holes through the support pipe and expansion bolt and connecting together with a 1/4" diameter bolt is an effective way to prevent the bolt from dislodging during certain wind and pressure conditions.

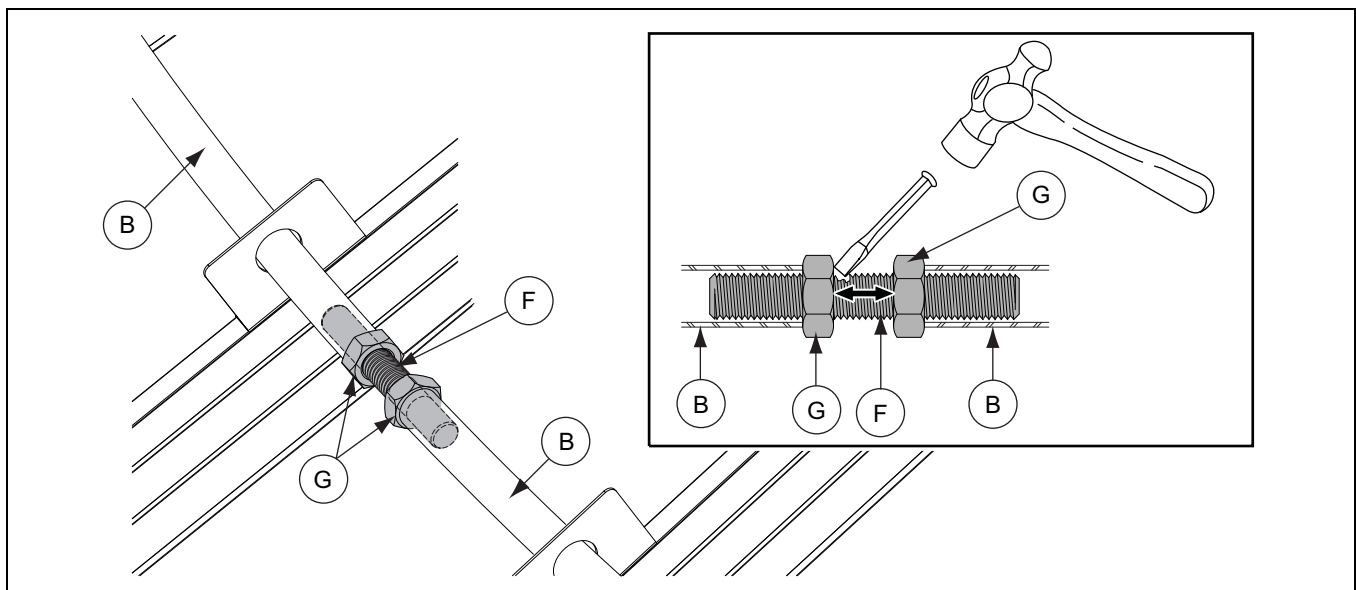

Figure 8U Exploded View of Threaded Stud

Ref #	Part #	Description
B		Roof Ring Section
F	S-8765	Threaded Stud

Ref #	Part #	Description
G	S-8926	Stud Nut

Assembling the Ladder Section

The inside ladder package consists of the ladder, starter brackets, standoff brackets, reinforcement straps, and ending bracket. The ladder should be assembled before installing it to the bin structure.

What You Should Know

When assembling the ladder sections, ensure all slip resistant ladder rungs are oriented in the same direction.

NOTE: A portion of the last ladder section may need to be cut to fit the proper length to the ground or to the intermediate platform.

1. Place two ladder sections (A) together as shown.
2. Install a splice plate (C) to each outside channel, connecting the ladder sections (A).
3. Install 5/16" flange bolts (D) to each inside channel as shown, connecting the ladder sections (A).
4. Install 5/16" flange nuts (B) to each outside channel as shown, securing the ladder sections (A).
Tighten to the recommended torque specifications. Refer to bolt torque specifications [on Page 30](#).

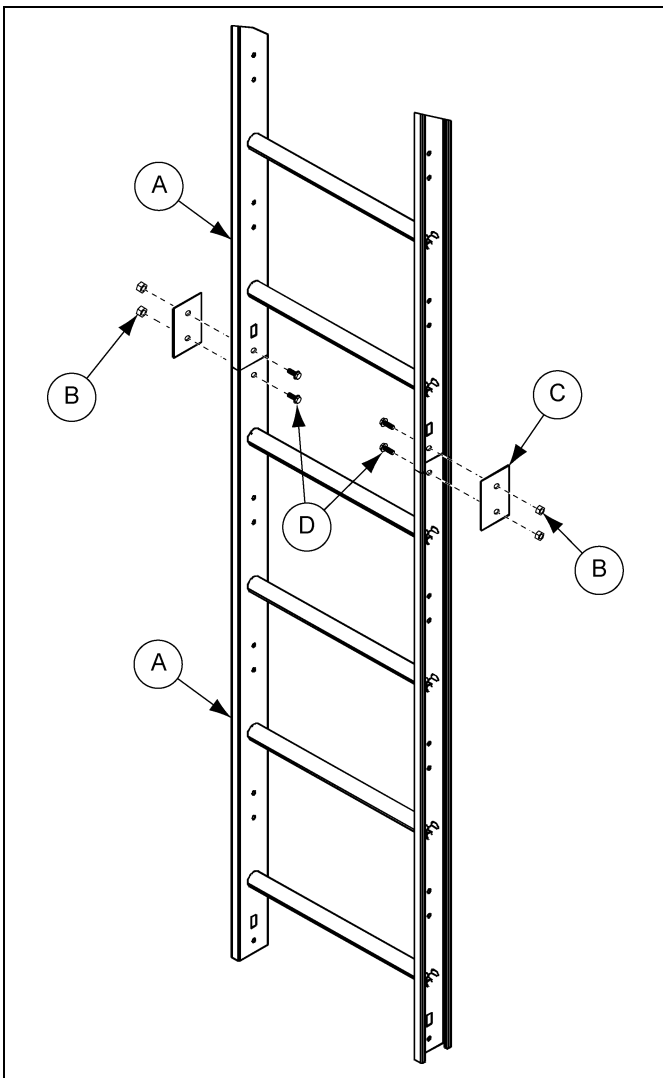

Ref #	Description
A	Ladder Section
B	5/16" Flange Nut (S-3611)
C	Splice Plate (LDR-4317)
D	5/16" x 1" Flange Bolt with Sealing Washer (S-10260)

Figure 9A Assembling the Inside Ladder Sections

Installing the Platform Support

1. Attach the platform mounting angles (C) to the sidewall (F) of the grain bin using 5/16" x 1" flange bolts (D) and 5/16" flange nuts (E).

NOTE: Use the platform mounting holes to attach the mounting angles.

NOTE: Tighten all the hardware.

2. Attach the support angles (B) to the platform mounting angles (C) using 5/16" x 1" flange bolts (D) and 5/16" flange nuts (E).
3. Install the brace angles (A) to the platform mounting angles (C) and support angles (B) using 5/16" x 1" flange bolts (D) and 5/16" flange nuts (E).

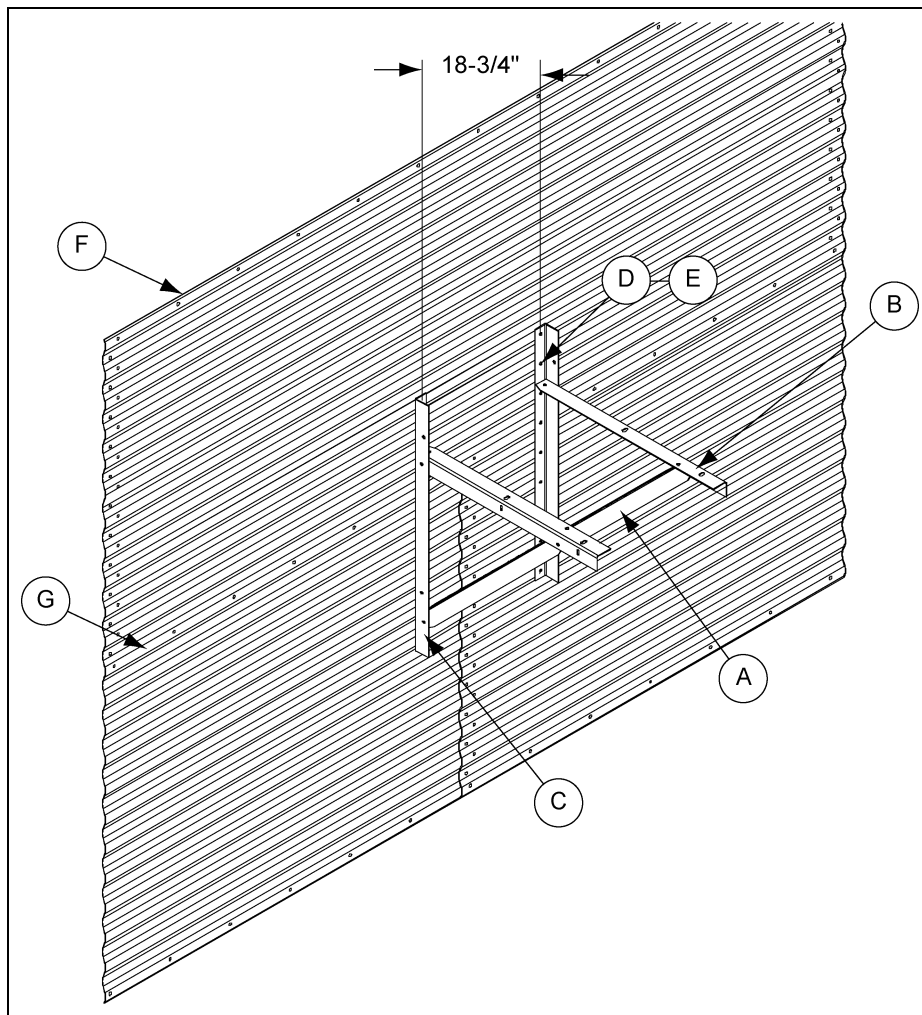

Figure 9B *Installing the Platform Support*

Ref #	Part #	Description
A	LS-369	30-3/4" Brace Angle
B	LS-370	28" Support Angle
C	LS-6705	35" Platform Mounting Angle
D	S-10260	5/16" x 1" Flange Bolt with Sealing Washer

Ref #	Description
E	5/16" Flange Nut (S-10268)
F	Sidewall
G	Horizontal Seam

Installing the Eave Adjustable Braces to Extension Rails and Roof

An eave adjustable brace assembly is comprised of one large diameter (center) tube (I) and two smaller diameter tubes (M).

1. Slide the smaller tubes (M) towards inside of the center tube (I) as shown.
2. Install the one end (H) of the smaller tube (M) to the top of ladder extension rail (K).
3. Adjust the flattened end (N) of smaller tube (M), until the flattened bottom (N) reaches the roof panel (J), then attach the flattened end (N) to the roof panel (J) as shown.
4. After securing both ends to the extension rail and the roof panel, field drill four 5/16" holes (R) through both center (I) and small tubes (M) and bolt together using 1/4" x 1-1/2" bolts (P) and 1/4" nuts (Q). This will connect all three pieces together to make a secure eave adjustable brace.

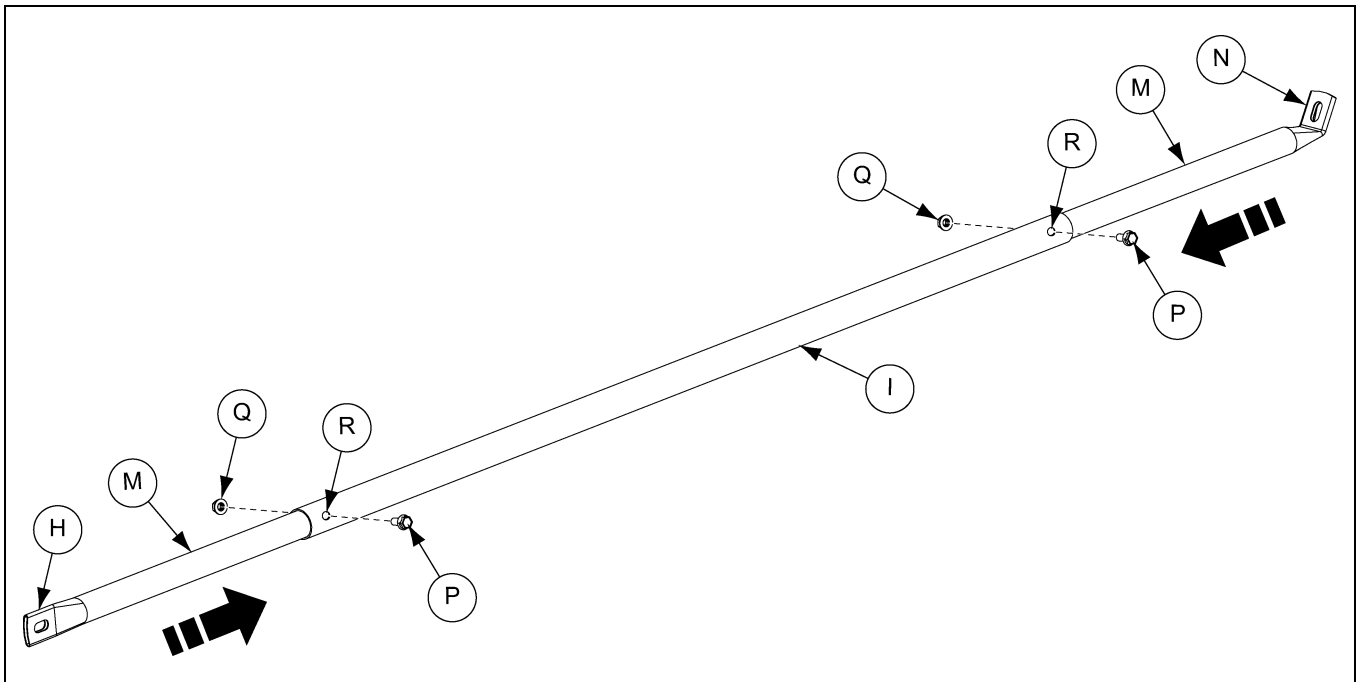

Figure 9C Eave Adjustable Brace Assembly

Ref #	Description
H	End Tube (LS-7031)
I	Center Tube (LS-6615)
M	Small Diameter Tube
N	Flattened Bottom End (LS-6616)
P	1/4" x 1-1/2" Bolt
Q	1/4" Nut
R	5/16" Field Drill Holes for Eave Adjustable Brace

9. Accessories

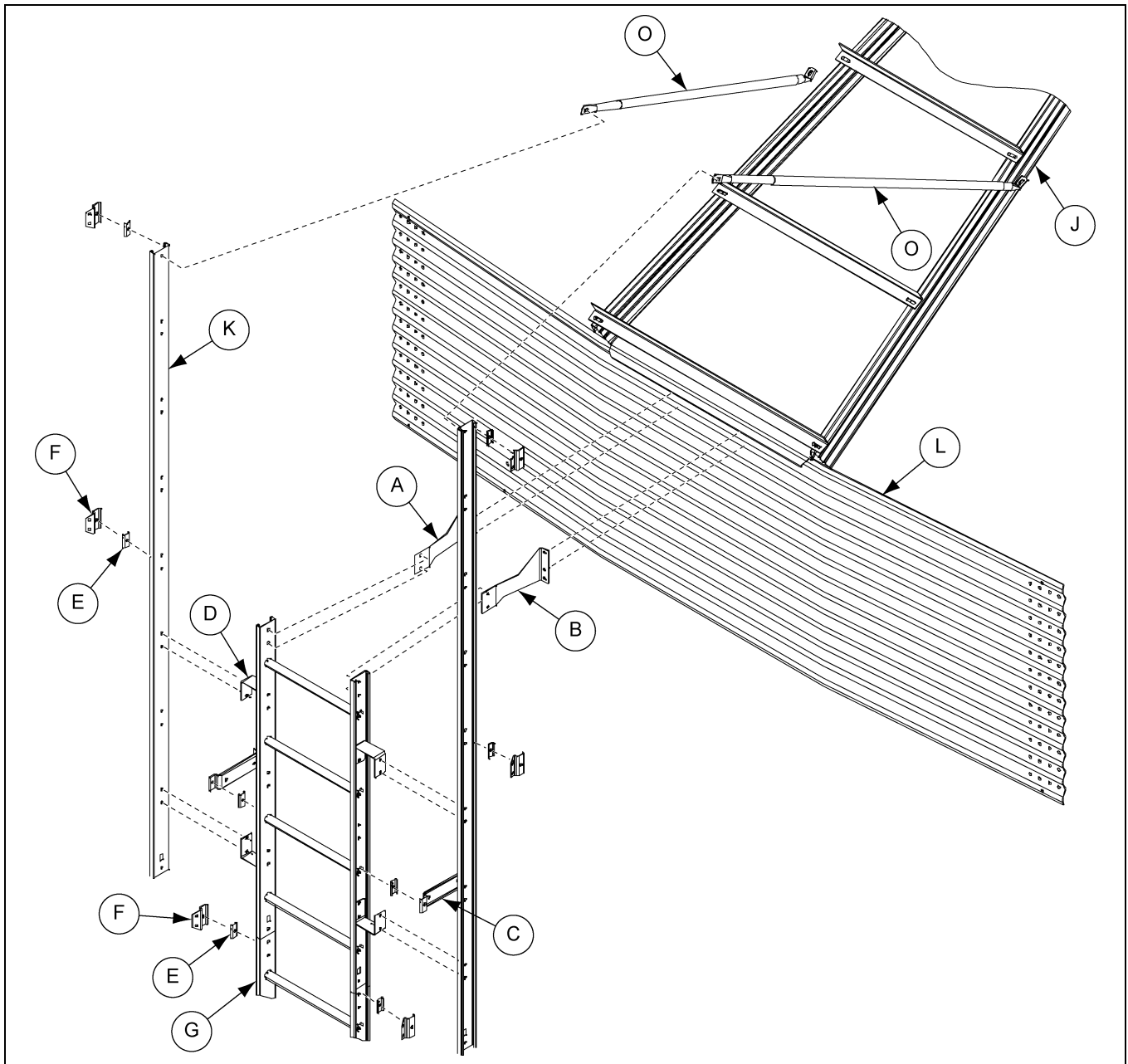

Figure 9D *Installing the Eave Adjustable Braces*

Ref #	Part #	Description
A	LDR-4346	L.H. Starter Bracket
B	LDR-4347	R.H. Starter Bracket
C	LDR-4314	Standoff Bracket
D	LDR-4403	Spacer Bracket
E	LDR-4198	Standoff Wedges
F	LDR-4199	Safety Cage Hoop Bracket

Ref #	Description
G	Ladder Section (LDR-4345)
J	Roof Panel
K	8' Extension Rail
L	Sidewall
O	Eave Adjustable Brace Assembly

Assembling the Platform and Handrail

1. Install the platform (C) to the platform supports using 5/16" x 1" flange bolts (H) and 5/16" flange nuts (I).
2. Install the vertical entrance angle (F) to the left front corner of the platform (C) using 5/16" x 1" flange bolts (H) and 5/16" flange nuts (I) as shown.
3. Install the remaining vertical angles (E) to the platform (C) using 5/16" x 1" flange bolts (H) and 5/16" flange nuts (I).
4. Install the safety cage extension angle (A) to the vertical entrance angle (F) and platform (C) using 5/16" x 1" flange bolts (H) and 5/16" flange nuts (I).
5. Install the safety cage hoop adapter angle (G) to the safety cage platform extension angle (A) using 5/16" x 1" flange bolts (H) and 5/16" flange nuts (I).
6. After all the vertical angles are in place, install the front and side handrails (B and D) to the vertical entrance angle (F) and handrail post (E) using 5/16" x 1" flange bolts (H) and 5/16" flange nuts (I).

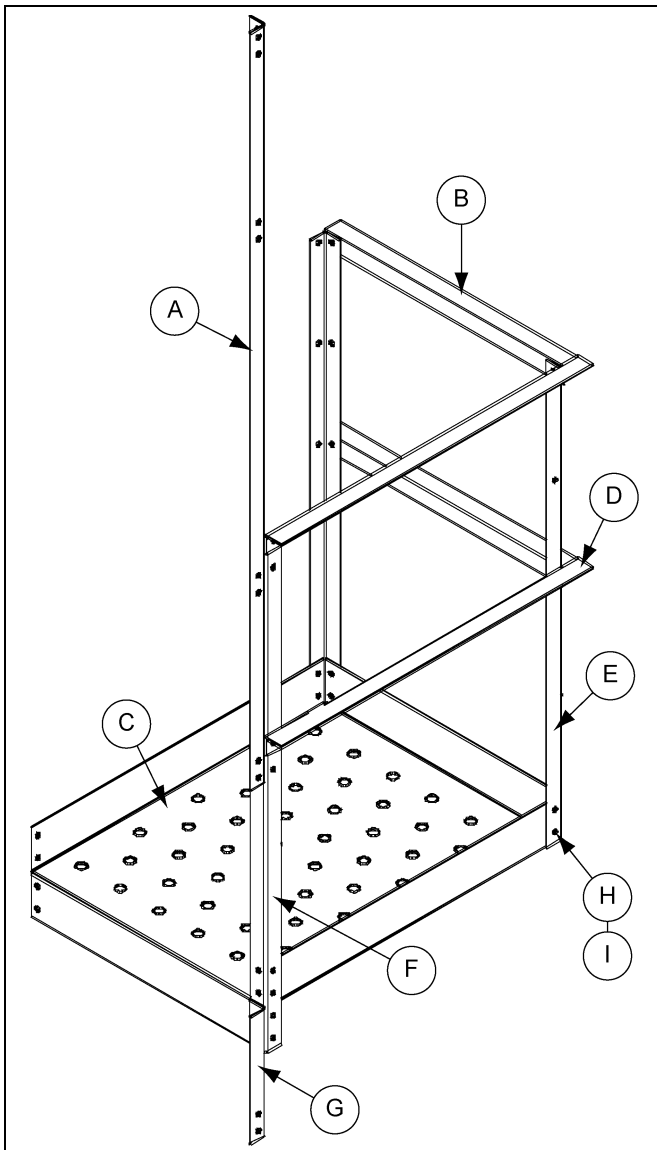

Ref #	Part #	Description
A	LS-6775	67-1/2" Safety Cage Platform Extension Angle (Safety Cage Only)
B	LS-294	24-7/16" Side Handrail
C	LS-373	Platform
D	LS-295	32-1/16" Front Handrail
E	LS-371	42" Handrail Post (Yellow)
F	LS-6621	46" Vertical Entrance Angle (Pink)
G	LS-6776	11-5/16" Safety Cage Hoop Adapter Angle (Safety Cage Only)
H	S-10260	5/16" x 1" Flange Bolt with Sealing Washer
I	S-10268	5/16" Flange Nut

Figure 9E Assembling the Platform and Handrail

Assembling the Eave Safety Cage Hoop

What You Should Know

Before attaching any pieces to the ladders of platform, some pre-assembly is required.

1. Install two safety cage hoop brackets (A) to the 8' extension rail (I) and one safety cage hoop bracket (A) to the second ladder section (H).
2. Install the one end of safety cage hoop adjuster plates (D) to the safety cage hoop adapter angle (C).
3. Install the safety cage hoop adapters (E) together and attach to the safety cage hoop halves (F).

NOTE: Install 5/16" x 1" flange bolt with bolt heads on the inside of the safety cage.

4. Attach another end of the safety cage hoop adapters (E) to the safety cage hoop adjuster plate (D).
5. Install the safety cage hoop halves (F) to the safety cage hoop brackets (A) and tighten the hardware.

NOTE: The bottom assembly requires two hoop halves (F) and will be positioned just below the platform as shown.

6. Attach the bottom two hoop half assemblies to the vertical entrance angle (G) and the safety cage hoop adapter angle (C) on the platform assembly.
7. Install the top hoop half assembly to the safety cage platform extension angle (B) as shown.

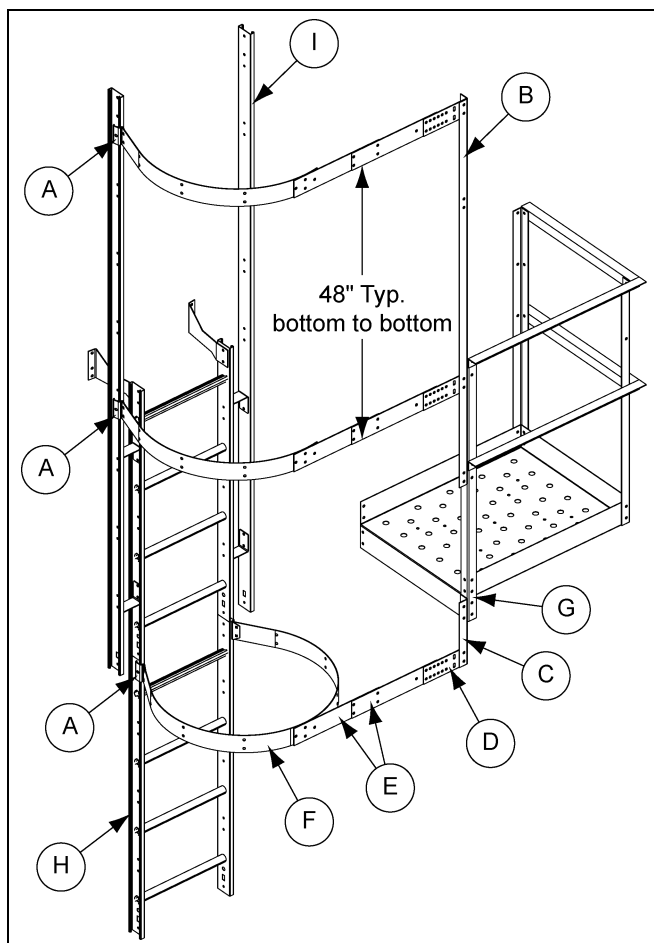

Ref #	Part #	Description
A	LDR-4199	Safety Cage Hoop Bracket
B	LS-6775	67-1/2" Safety Cage Platform Extension Angle (Safety Cage Only)
C	LS-6776	11-5/16" Safety Cage Hoop Adapter Angle (Safety Cage Only)
D	LS-5285	Safety Cage Hoop Adjuster Plate
E	LS-5284	Safety Cage Hoop Adapter
F	LS-4201	Safety Cage Hoop Half
G	LS-6621	46" Vertical Entrance Angle
H	LDR-4345	Top Ladder Section
I		8' Extension Rail

Figure 9F Assembling the Eave Safety Cage Hoop

Safety Cage Hoop Adjuster Plate Connection Details

Refer the below figure to determine the proper holes used when attaching the hoop adapters to the safety cage hoop adjuster plate.

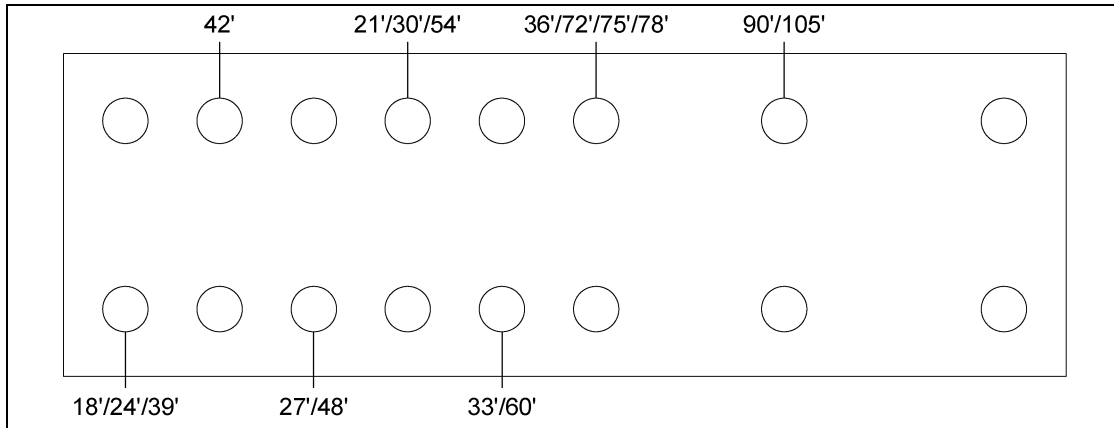

Figure 9G Safety Cage Hoop Adjuster Plate Connection Details

Installing the Vertical Supports

Before You Begin

Before installing vertical supports make sure the three hoop assemblies are in place.

1. Install the safety cage vertical supports (A) from one hoop assembly (E) to the another hoop assembly (E) using the 5/16" x 1" flange bolts (C) and 5/16" flange nuts (D). Also remember to use the 5/16" x 1-1/4" bin bolts (B) and 5/16" flange nuts (D) at hoop assembly overlaps.

NOTE: This will require ten supports, five between each set of hoops.

2. The second set of safety cage vertical supports (A) will need to be bent at the flat area to allow for the tapering of the bottom hoop assembly (E).

NOTE: Install 5/16" x 1" flange bolts (C) with bolt heads on the inside of the safety cage.

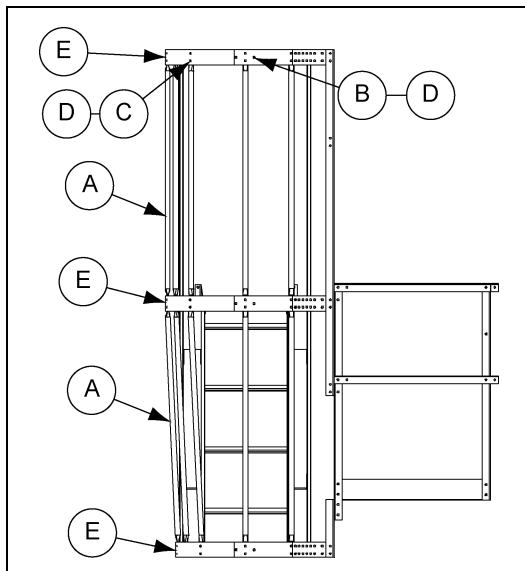

Figure 9H Installing the Vertical Supports

Ref #	Part #	Description
A	LS-6713	48" Safety Cage Vertical Support
B	S-7483	5/16" x 1-1/4" Bin Bolt
C	S-10260	5/16" x 1" Flange Bolt with Sealing Washer
D	S-10268	5/16" Flange Nut
E		Safety Cage Hoop Assembly

Assembling the Safety Cage

1. Install the safety cage vertical supports (F) to the existing safety cage hoop halves (D) in the ladder (H) using the 5/16" x 1" flange bolts (G) and 5/16" flange nuts (C).

NOTE: Install 5/16" x 1" flange bolts (G) with bolt heads on the inside of the safety cage.

2. Assemble the two safety cage hoop halves (D) together and install it to the other end of the safety cage vertical supports (F) using the 5/16" x 1" flange bolts (G) and 5/16" flange nuts (C).
3. Install the safety cage hoop bracket (A) to the ladder (H) using 5/16" x 1" carriage bolts (B), standoff wedges (E) and 5/16" flange nuts (C) as shown.

NOTE: Leave hardware loosen until the safety cage hoop half (D) has been installed.

4. Attach the safety cage hoop halves (D) to the safety cage hoop brackets (A) on the ladder (H) using the 5/16" x 1" flange bolts (G) and 5/16" flange nuts (C).
5. Repeat the [Step 1-4](#) to assemble the each safety cage if required.

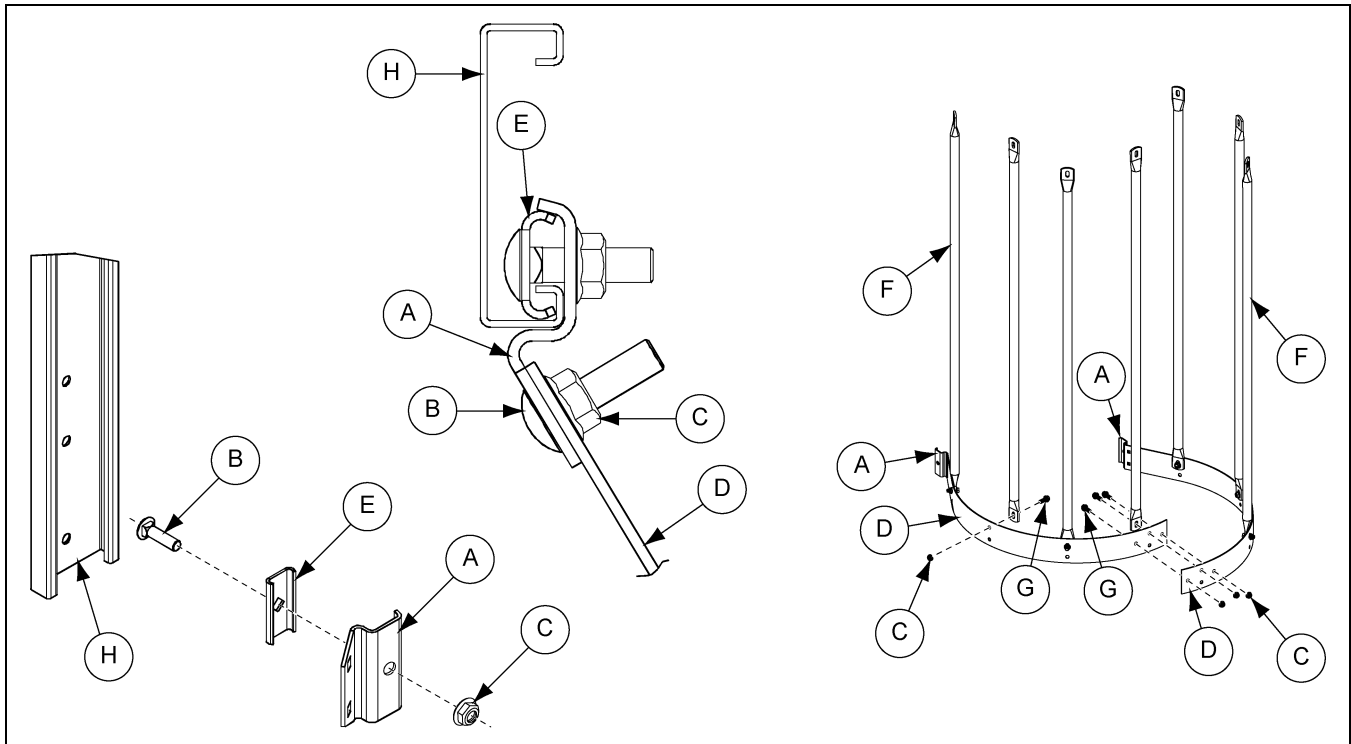

Figure 91 Assembling the Safety Cage Extension

Ref #	Part #	Description
A	LDR-4199	Safety Cage Hoop Bracket
B	S-3550	5/16" x 1" Carriage Bolt
C	S-10268	5/16" Flange Nut
D	LDR-4201	Safety Cage Hoop Half

Ref #	Part #	Description
E	LDR-4198	Standoff Wedge
F	LS-6713	48" Safety Cage Vertical Support
G	S-10260	5/16" x 1" Flange Bolt with Sealing Washer
H		Ladder

Assembling the 24" Safety Cage Bell Section

1. Install the safety cage vertical supports (A) to the hoop half assembly from the final safety cage installation using the 5/16" x 1" flange bolts (C) and 5/16" flange nuts (D).

NOTE: Install 5/16" x 1" flange bolts (C) with bolt heads on the inside of the safety cage.

2. Assemble the two special bell safety cage hoop halves (B) together and install it to the other end of safety cage vertical supports (A) using the 5/16 x 1" flange bolts (C) and 5/16" flange nuts (D).

NOTE: The safety cage vertical supports (A) must be bent at the flat area to allow for the bell section angle.

3. Install the safety cage brackets to the ladder using 5/16" x 1" carriage bolts, standoff wedges and 5/16" flange nuts. (See Figure 9I on Page 74.)

NOTE: Leave the hardware loosen until the special bell safety cage hoop half (B) has been installed.

4. Install the other end of the safety cage hoop bracket to the special safety cage bell hoop halves (B) using 5/16" x 1" carriage bolts and 5/16" flange nuts (D).

NOTE: The safety cage bell section is to be used at the point of termination of the safety cage and should be just above the concrete (generally 7-8').

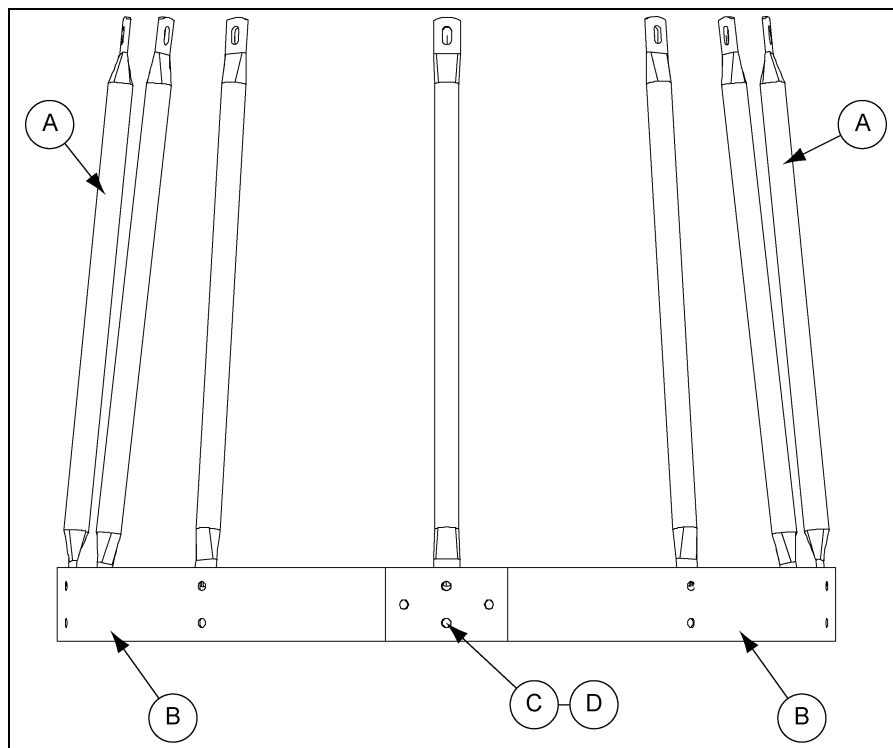

Figure 9J Assembling the 24" Safety Cage Bell Section

Ref #	Part #	Description
A	LS-6714	24" Safety Cage Vertical Support
B	LDR-4202	Safety Cage Bell Hoop Halves
C	S-10260	5/16" x 1" Flange Bolt with Sealing Washer
D	S-10268	5/16" Flange Nut

NOTES

Limited Warranty — N.A. Grain Products

The GSI Group, LLC. (“GSI”) warrants products which it manufactures, to be free of defects in materials and workmanship under normal usage and conditions for a period of 12 months from the date of shipment (or, if shipped by vessel, 14 months from the date of arrival at the port of discharge). If, in GSI’s sole judgment, a product is found to have a defect in materials and/or workmanship, GSI will, at its own option and expense, repair or replace the product or refund the purchase price. This Limited Warranty is subject to extension and other terms as set forth below.

Warranty Enhancements: The warranty period for the following products is enhanced as shown below and is in lieu of (and not in addition to) the above stated warranty period. (Warranty Period is from date of shipment.)

	Product	Warranty Period
Storage	Grain Bin Structural Design • Sidewall, roof, doors, platforms and walkarounds • Flooring (when installed using GSI specified floor support system for that floor) • Hopper tanks (BFT, GHT, NCHT, and FCHT)	5 Years
Conditioning	Dryer Structural Design – (Tower, Portable and TopDry) • Includes (frame, portable dryer screens, ladders, access doors and platforms)	5 Years
	All other Dryer parts including: • Electrical (controls, sensors, switches and internal wiring)	2 Years
	All Non-PTO Driven Centrifugal and Axial Fans	3 Years
	Bullseye Controllers	2 Years
Material Handling	Bucket Elevators Structural Design	5 Years
	Towers Structural Design	5 Years
	Catwalks Structural Design	5 Years
	Accessories (stairs, ladders and platforms) Structural Design	5 Years

Conditions and Limitations:

THERE ARE NO WARRANTIES THAT EXTEND BEYOND THE LIMITED WARRANTY DESCRIPTION SET FORTH HEREIN; SPECIFICALLY, GSI DISCLAIMS ANY AND ALL OTHER WARRANTIES OF ANY KIND, EXPRESS OR IMPLIED, INCLUDING, WITHOUT LIMITATION, WARRANTIES OF MERCHANTABILITY OR FITNESS FOR A PARTICULAR PURPOSE OR USE IN CONNECTION WITH: (I) ANY PRODUCT MANUFACTURED OR SOLD BY GSI, OR (II) ANY ADVICE, INSTRUCTION, RECOMMENDATION OR SUGGESTION PROVIDED BY AN AGENT, REPRESENTATIVE OR EMPLOYEE OF GSI REGARDING OR RELATED TO THE CONFIGURATION, INSTALLATION, LAYOUT, SUITABILITY FOR A PARTICULAR PURPOSE, OR DESIGN OF SUCH PRODUCTS.

The sole and exclusive remedy for any claimant is set forth in this Limited Warranty and shall not exceed the amount paid for the product purchased. This Warranty only covers the value of the warranted parts and equipment, and does not cover labor charges for removing or installing defective parts, shipping charges with respect to such parts, any applicable sales or other taxes, or any other charges or expenses not specified in this Warranty. GSI shall not be liable for any other direct, indirect, incidental or consequential damages, including, without limitation, loss of anticipated profits or benefits. Expenses incurred by or on behalf of a claimant without prior written authorization from the GSI warranty department shall not be reimbursed. This warranty is not transferable and applies only to the original end-user. GSI shall have no obligation or responsibility for any representations or warranties made by or on behalf of any dealer, agent or distributor. Prior to installation, the end-user bears all responsibility to comply with federal, state and local codes which apply to the location and installation of the products.

This Limited Warranty extends solely to products sold by GSI and does not cover any parts, components or materials used in conjunction with the product, that are not sold by GSI. GSI assumes no responsibility for claims resulting from construction defects, unauthorized modifications, corrosion or other cosmetic issues caused by storage, application or environmental conditions. Modifications to products not specifically delineated in the manual accompanying the product at initial sale will void all warranties. This Limited Warranty shall not extend to products or parts which have been damaged by negligent use, misuse, alteration, accident or which have been improperly/inadequately maintained.

Notice Procedure:

In order to make a valid warranty claim a written notice of the claim must be submitted, using the RMA form, within 60 days of discovery of a warrantable nonconformance. The RMA form is found on the OneGSI portal.

Service Parts:

GSI warrants, subject to all other conditions described in this Warranty, Service Parts which it manufactures for a period of 12 months from the date of purchase unless specified in Enhancements above.

This equipment shall be installed in accordance with the current installation codes and applicable regulations, which should be carefully followed in all cases. Authorities having jurisdiction should be consulted before installations are made.



**1004 E. Illinois St.
Assumption, IL 62510-0020
Phone: 1-217-226-4421
Fax: 1-217-226-4420
www.gsiag.com**



GSI is a worldwide brand of AGCO Corporation.